



Integration Strategy to Improve Competitive Advantage and Marketing Performance of Culinary MSMEs in Ambon City

Walter Tabelessy

Pattimura University, Ambon

Corresponding Author: Walter Tabelessy, wtabelessy@gmail.com

ARTICLE INFO

Keywords: Digital Marketing, Product Innovation, CRM, Competitive Advantage, Marketing Performance

Received : 11 July

Revised : 23 August

Accepted : 28 September

©2024 Tabelessy: This is an open-access article distributed under the terms of the [Creative Commons Attribution 4.0 International](https://creativecommons.org/licenses/by/4.0/)



ABSTRACT

In the dynamic era of globalization, Micro, Small, and Medium Enterprises (MSMEs) in Indonesia face major challenges in achieving competitive advantage. MSMEs, which also play an important role in the national economy, often find it difficult to adapt to the latest trends such as digital marketing. Digital marketing provides great opportunities for MSMEs to expand market reach and increase interaction with consumers, but its effectiveness in increasing competitive advantage is still debated. This study examines how the integration of digital marketing, product innovation, and customer relationship management (CRM) funds can strengthen the competitive advantage of MSMEs, especially in the culinary sector in Ambon City. Using the Partial Least Square Structural Equation Modeling (PLS-SEM) method, this study involved 155 culinary MSME actors to test the three elements against competitive advantage and marketing performance. The results showed that digital marketing, product innovation, and CRM significantly influenced competitive advantage, which also had a positive impact on marketing performance. These findings support the importance of holistic strategy integration to increase the competitiveness of MSMEs in the global market and provide insights for the development of relevant theoretical models

INTRODUCTION

In this era of increasingly rapid globalization, changes in the business world are taking place very quickly. The need to adapt to the latest trends is the main key to the success of an organization, especially for Micro, Small, and Medium Enterprises (MSMEs). MSMEs act as the backbone of the economy in many countries, including Indonesia. The development of MSMEs not only contributes greatly to Gross Domestic Product (GDP), but also creates jobs and promotes innovation at the local level (Bayraktar & Algan, 2019). However, amidst increasingly fierce competition, many MSMEs face serious challenges in terms of competitive advantage and marketing performance (Bin Khunin & Al-Nsour, 2024). In order to survive and thrive, MSMEs must be able to integrate various elements of business strategy more effectively and efficiently. One approach that can be applied is to implement digital marketing. This approach allows MSMEs to utilize digital technology to reach a wider consumer base.

Digital marketing is very important for MSMEs in increasing competitive advantage because this strategy provides an effective and efficient method to reach and interact with the right consumers, and increase brand visibility (Ago et al., 2023; Danurdara et al., 2024). By implementing this strategy, MSMEs can compete better in the global market. The impacts include increased brand awareness, higher customer loyalty, and having the ability to adapt to market changes quickly, which overall can increase competitive advantage.

MSME actors in the current digital era must be able to implement digital marketing in marketing their products or services because it greatly contributes to competitive advantage (Nadanyiova et al., 2021), in contrast to the latest findings from (Graciafernandy et al., 2024) which prove that digital marketing does not contribute to competitive advantage. The difference in research results between those that support the contribution of digital marketing to competitive advantage and those that reject this contribution, shows a gap in understanding and empirical evidence regarding the effectiveness of digital marketing in the context of MSMEs. Due to these limitations, the researchers in this study will analyze how other factors such as product innovation and customer relationship management (CRM) can also contribute to competitive advantage. The focus will be on how product innovation and CRM can strengthen the impact of digital marketing on competitive advantage and the specific conditions under which these three factors have a significant impact. In addition, this study will also examine the influence of competitive advantage on marketing performance, because a deep understanding of this relationship can help MSMEs identify effective strategies to improve marketing performance.

One of the MSME sectors that is growing with the largest use of digital applications in Indonesia is the culinary sector. More about the use of digital applications in this sector can be seen in the following graph:

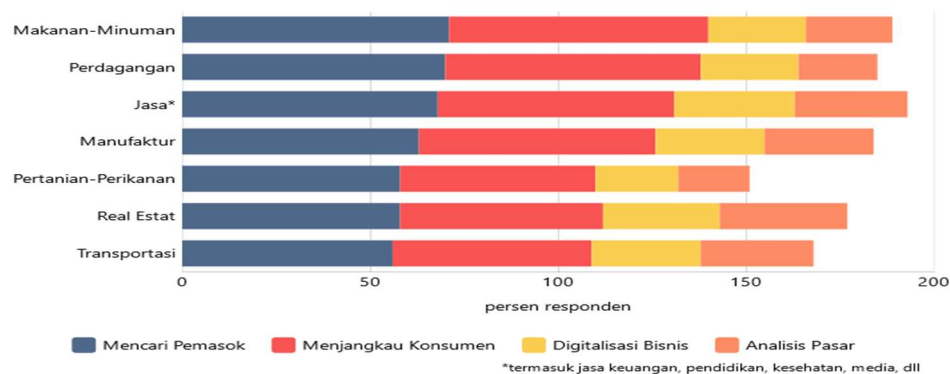

Source: Boston Consulting Group (BCG) and Telkom Indonesia

Figure 1. MSME Sector that Makes the Most Use of Digital Applications

Figure 1 means that the culinary sector uses 69% of digital applications to reach consumers. However, in this high percentage, culinary MSME respondents who have implemented business digitalization are still low, which is only 26%. In addition, the use of market analysis tools in this sector is still relatively low, only 23% (<https://databoks.katadata.co.id>).

The increase in the number of MSMEs in Maluku Province has also experienced growth, with a total of 55,675 MSME actors in 2018, increasing to 149,000 in 2022, driven by the culinary sector (Tabelessy & Turukay, 2024). Likewise, what happened in Ambon City, with 14,000 MSME actors before the COVID Pandemic and in 2022 to 60,000 MSME actors who are still dominated by the culinary sector (Antara Maluku, October 29, 2022). The increase in the number of culinary MSMEs is not directly proportional to the mastery of digital applications.

Based on the research findings and the MSME business phenomena that have been described, the problem faced in this study is the contradiction of perspectives and research results related to the integration of strategies to improve competitive advantage and marketing performance. Therefore, this study aims to explore strategies that effectively integrate digital marketing, product innovation, and CRM as the development of a relevant theoretical model and provide deeper insight into optimizing these strategies to improve competitive advantage and marketing performance of culinary MSMEs in Ambon City.

LITERATURE REVIEW

Digital marketing has emerged as a very powerful approach in modern marketing strategies (Yunarti et al., 2024). Digital marketing refers to the process of promoting products or services by utilizing digital technology, especially through the internet. It also includes the use of mobile phones, graphic advertising, and various other forms of digital media (Desai, 2019). By utilizing digital platforms such as social media, e-commerce and search engines, MSMEs can reach potential customers worldwide at a relatively low cost compared to conventional marketing. Digital marketing not only expands market reach but also allows for more direct and personal interactions with customers (Dašić et al., 2023). With digital marketing, it will have an impact on competitive advantage

because it is important for the sustainability of MSME businesses (Ralahallo et al., 2024). This is proven by the results of research from (Asikin et al., 2024) which states that digital marketing has an impact on competitive advantage. Based on the various descriptions that have been put forward, the first hypothesis in this study is:

H1: Digital Marketing has a Significant Influence on Competitive Advantage.

Product innovation is one of the main pillars in a business strategy that aims to create added value for customers and increase competitiveness (Jusuf, 2022; Reguia, 2014). This innovation not only includes the development of new products, but also the improvement of existing products to meet the needs and desires of consumers and continues to change (Fauziah et al., 2022). In the context of MSMEs, product innovation often faces various obstacles, such as limited resources and limited knowledge of the latest market trends (Hakim, 2024). Although MSMEs have the potential to create unique and different products, MSMEs also often have difficulty in translating innovative ideas into successful products in the market. To realize all of this, a strong entrepreneurial spirit is needed, namely having creative ideas (Tablelessy et al., 2022). Product innovation must be carried out by MSMEs because it will have an impact on competitive advantage. This statement is proven by the results of research conducted by (Pramuki & Kusumawati, 2021) and (Kuncoro & Suriani, 2018) which confirm that product innovation has an influence on competitive advantage. Based on the various descriptions that have been put forward, the second hypothesis in this study is:

H2: Product Innovation has a Significant Influence on Competitive Advantage.

On the other hand, CRM is a concept that emphasizes the importance of building and maintaining good relationships with customers to increase customer satisfaction and loyalty (Athirah Imran et al., 2022; Nurfaizah & Marsasi, 2024). CRM not only involves the use of technology to manage customer data but also strategies to improve customer experience and build long-term relationships (Gil-Gomez et al., 2020). Effective CRM can provide valuable insights into customer preferences and help in creating offerings that better suit their needs (Anshari et al., 2019). Thus, CRM also has an impact on competitive advantage (Musonnafa et al., 2022; Sopyan et al., 2018). However, many MSMEs still do not understand how CRM can be implemented effectively in the business they manage. Based on the theory and previous research described above, the third hypothesis in this study is:

H3: CRM has a Significant Influence on Competitive Advantage.

The integration of digital marketing, product innovation, and CRM is a holistic approach to increasing competitive advantage which ultimately contributes to the marketing performance of MSMEs (Handoyo, 2015; Sukaatmadjaa et al., 2021). These three elements are interrelated and mutually reinforce each other. A good digital marketing strategy can support the success of product innovation to be better known to consumers, and effective CRM can help in understanding customer needs and developing better products. However, the main challenge is how to integrate these three elements synergistically to increase competitive advantage which has an impact on marketing performance. The results of the study (Yasa et al., 2020)), confirm that

competitive advantage has an influence on marketing performance. Based on the theory and previous research described above, the fourth hypothesis in this study is:

H4: Competitive Advantage has a Significant Influence on Marketing Performance.

Referring to the various explanations that have been given previously, the research framework in this study can be described as follows:

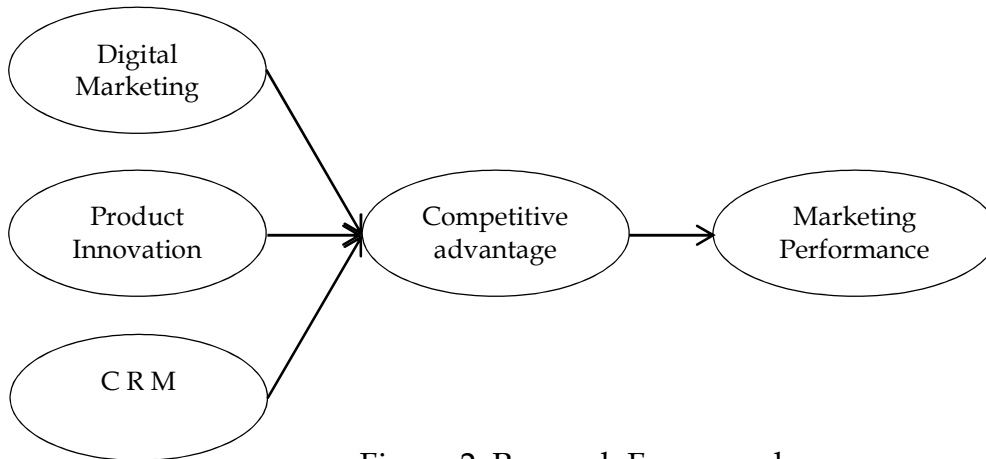

Figure 2. Research Framework

METHODOLOGY

This study uses a data analysis technique, namely Partial Least Square Structural Equation Modeling (PLS-SEM), so that in determining the number of samples using the inverse square root technique (Ezeugwa et al., 2022; Tabelessy & Pattiruhu, 2024). Based on this technique, a sample of 155 culinary sector MSME actors in Ambon City was obtained. The questionnaire survey was conducted using a purposive sampling technique, namely determining the sample based on certain criteria determined by the researcher (Tubalawony; et al., 2023), with a time between June and August 2024.

The questionnaire distributed to respondents consisted of 5 parts, namely digital marketing, product innovation, CRM, competitive advantage, and marketing performance. The digital marketing (DM) construct is based on indicators quoted from (Purwanti et al., 2022). The product innovation (PI) construct is based on indicators quoted from (Gutiérrez-Broncano et al., 2024). CRM construct is based on indicators cited from (Hat et al., 2024). Competitive advantage (CA) construct is based on indicators cited from (Kuncoro & Suriani, 2018). Marketing performance (MP) construct is based on indicators cited from (Tabelessy; et al., 2024). Measurement of these constructs is based on a Likert scale of 1-5.

The data analysis technique used in this study is the PLS-SEM method which requires several requirements, including a complex relationship (Afthanorhan et al., 2020; Tabelessy, 2024). Based on the research framework, these requirements have been met so that this method can be used. To assist data processing, the ADANCO application is used, which is one of the applications for processing PLS-based data (Henseler, 2017).

RESULT AND DISCUSSION

Measurement Model

Table 1. Reliability Test Results

Construct	Dijkstra-Henseler's rho (ρ_A)	Jöreskog's rho (ρ_c)	Cronbach's alpha (α)
DM	0,8486	0,8471	0,8468
PI	0,8337	0,8162	0,8170
CRM	0,9156	0,8933	0,9015
CA	0,7207	0,7106	0,7205
MP	0,8695	0,8433	0,8385

Source: Data Processing Results, 2024

According to (Benitez et al., 2020), the values of Dijkstra's Henseler rho (ρ_A), Jöreskog's rho (ρ_c), and Cronbach's alpha (α) should exceed 0.7. Based on the results listed in table 1, it can be concluded that all constructs show a good level of reliability.

Table 2. Convergent Validity Test Results

Construct	Average variance extracted (AVE)
DM	0,5812
PI	0,6006
CRM	0,6330
CA	0,5528
MP	0,6472

Source: Data Processing Results, 2024

According to (Benitez et al., 2020), the Average Variance Extracted (AVE) value should be more than 0.5. Based on the test results listed in table 2, it can be concluded that all constructs show good convergent validity.

Table 3. Discriminant Validity Test Results

Construct	DM	PI	CRM	CA	MP
DM					
PI	0,3512				
CRM	0,2036	0,3659			
CA	0,5138	0,4631	0,4037		
MP	0,6465	0,3977	0,4367	0,6303	

Source: Data Processing Results, 2024

According to (Benitez et al., 2020), the Heterotrait–Monotrait (HTMT) value should be less than 0.85 or 0.90. Based on the results presented in table 3, it can be concluded that all constructs show good discriminant validity.

Structural Model

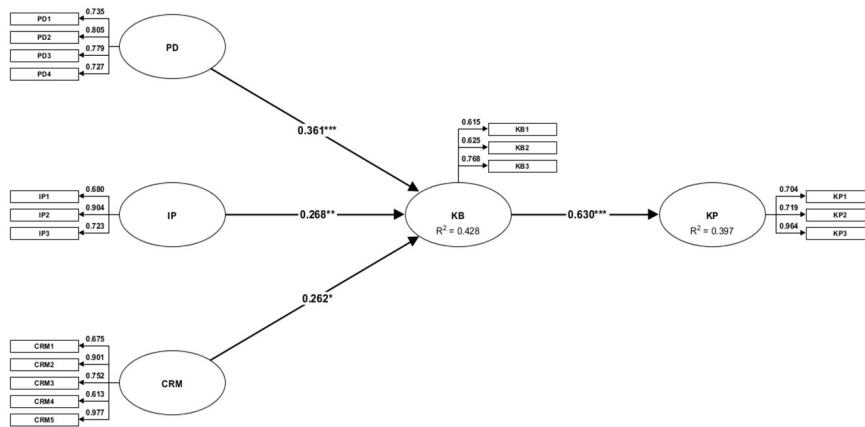

Source: Data Processing Results, 2024
 Figure 3. Structural Model

Table 5. R-Square Test Results

Construct	R-Square
Competitive Advantage	0,428
Marketing Performance	0,397

According to (Henseler et al., 2016), the R-Square (R2) value in modeling is categorized as strong (0.75), moderate (0.50), and weak (0.25). Table 5 shows that all R2 values in this study are included in the moderate criteria.

Table 6. Hypothesis Testing Results

Effect	Original coefficient	Standard bootstrap results				
		Mean Value	Standar Error	t-value	p-value (2 sided)	p-value (1 sided)
DM -> CA	0,3609	0,3668	0,1044	3,4582	0,0006	0,0003
PI -> CA	0,2679	0,2732	0,0988	2,7108	0,0068	0,0034
CRM -> CA	0,2623	0,2598	0,1098	2,3889	0,0171	0,0085
CA -> MP	0,6301	0,6341	0,0881	7,1505	0,0000	0,0000

Source: Data Processing Results, 2024

According to (Benitez et al., 2020), to accept a hypothesis, the p-value must be less than the set significance level (0.05), which means that the path coefficient shows a significant relationship between constructs. Table 6 shows the test results for the proposed hypothesis at a significance level of 5%, so it can be interpreted as follows:

H1: Digital Marketing has a Significant Influence on Competitive Advantage

The results of the hypothesis test show that digital marketing has a coefficient of 0.3609, a t-value of 3.4582 which is greater than 1.96, and a p-value of 0.0003 which is less than 0.05 so that the first hypothesis is accepted, namely digital marketing has a significant influence on competitive advantage.

In digital marketing, culinary MSME actors must understand that customer information, customer needs, customer relationships, and communication with

customers can directly affect competitive advantage. By collecting and analyzing customer information, culinary MSMEs can create and even develop products and services that are truly unique and meet specific customer needs. Well-established relationships enable culinary MSMEs to build customer loyalty, create products and services that are difficult to imitate, and strengthen the position of culinary MSMEs in the competitive market. Effective communication with customers can support competitive pricing strategies while providing transparent and adequate information, and ensuring that culinary MSME products remain the main choice that is rarely found in the market. Thus, a digital marketing strategy that focuses on these factors can increase competitive advantage by creating and even developing products and services that are not only difficult to imitate but also offer more value to customers. This finding is in line with the studies conducted (Asikin et al., 2024; Nadanyiova et al., 2021).

H2: Product Innovation has a Significant Influence on Competitive Advantage

The results of the hypothesis test show that product innovation has a coefficient of 0.2679, a t-value of 2.7108 which is greater than 1.96, and a p-value of 0.0034 which is smaller than 0.05 so that the second hypothesis is accepted, namely that product innovation has a significant influence on competitive advantage.

Product innovation that includes improvements, enhancements and new product launches can significantly strengthen the competitive advantage of culinary MSMEs. Continuous product improvements and enhancements enable culinary MSMEs to offer better and more efficient products, which can ultimately increase the uniqueness of the product itself in the market. By launching new, more innovative products, MSMEs can provide different offers from competitors, while providing added value to customers. This not only makes the product more attractive, but also strengthens the competitive price position by offering various benefits that are not easily replaced by competitors. Overall, an effective innovation strategy can create sustainable competitive advantage while keeping the product relevant, unique, and difficult to imitate in a competitive market. This finding is in line with studies conducted by (Kuncoro & Suriani, 2018; Pramuki & Kusumawati, 2021).

H3: CRM has a Significant Influence on Competitive Advantage

The results of the hypothesis test show that CRM has a coefficient of 0.2623, a t-value of 2.3889 which is greater than 1.96, and a p-value of 0.0085 which is smaller than 0.05 so that the third hypothesis is accepted, namely CRM has a significant influence on competitive advantage.

CRM strategy plays an important role in creating competitive advantage by utilizing customer personal information to offer products and services that will increase the uniqueness of the product in the market. With various functions designed to improve the customer experience, CRM strategy helps in creating offers that are difficult for competitors to imitate. The process-based approach in CRM ensures that interactions with customers can be managed consistently, creating products and services that are rarely found. Good technology orientation in CRM allows culinary MSMEs to stay at the forefront of innovation, while CRM reliability ensures that culinary MSMEs can offer competitive prices without sacrificing product or service quality, keeping products relevant and

difficult to replace for customers. This finding is in line with studies conducted by (Musonnafa et al., 2022; Sopyan et al., 2018).

H4: Competitive Advantage has a Significant Influence on Marketing Performance

The results of the hypothesis test show that competitive advantage has a coefficient of 0.6301, a t-value of 7.1505 which is greater than 1.96, and a p-value of 0.0000 which is less than 0.05 so that the fourth hypothesis is accepted, namely competitive advantage has a significant influence on marketing performance.

Competitive advantages that include product uniqueness, difficulty to imitate, scarcity in the market, competitive prices, and resistance to substitution play an important role in determining marketing performance, which is clearly seen through the success of new products, sales growth, and profits obtained. Unique and difficult-to-imitate products often achieve significant success when launched, because they offer something that is rarely found and not easily replaced by other alternatives. This greatly helps rapid sales growth, due to the strong appeal of the product and clear added value for customers. With competitive prices that focus on profit, MSMEs can ensure good annual profit margins, confirming the effectiveness of marketing strategies in securing product positions in competitive markets. Thus, effective competitive advantages underlie the achievement of successful and sustainable marketing results. This finding is in line with a study conducted by (Yasa et al., 2020).

CONCLUSION AND RECOMMENDATION

In the context of MSMEs, digital marketing, product innovation, and CRM have been shown to play a significant role in improving competitive advantage and marketing performance. This study shows that digital marketing and product innovation both have a significant impact on the competitive advantage of culinary MSMEs in Ambon City, while CRM also contributes to this improvement. Furthermore, competitive advantage directly affects marketing performance, with products or services that are unique and difficult to imitate and have the potential to provide better marketing results. The results of this study add empirical evidence that the integration of digital marketing strategies, product innovation, and CRM can help culinary MSMEs strengthen their position in an increasingly competitive market. MSMEs, especially in the culinary sector in Ambon City, should focus more on integrating digital marketing with product innovation and CRM to improve competitive advantage. Digital marketing can be used to reach more customers, while product innovation must be improved to meet consumer needs and desires that can change at any time. Effective CRM will help build long-term relationships with customers and manage data efficiently. By integrating and optimizing these three elements together, culinary MSMEs can strengthen their competitive advantage and improve overall marketing performance.

REFERENCES

- Afthanorhan, A., Awang, Z., & Aimran, N. (2020). Five common mistakes for using partial least squares path modeling (PLS-PM) in management research. *Contemporary Management Research*, 16(4), 255–278. <https://doi.org/10.7903/CMR.20247>
- Ago, G., Bayu, Hierdawati, T., Gani, I. P., Sudha, N. L. K. A., & Sucandrawati. (2023). SELECTION OF MARKETING STRATEGIES THROUGH ONLINEMARKETING PLATFORMS FOR MSMEs. *Jurnal Ekonomi*, 12(1), 874–878. <https://medium.com/@arifwicaksanaa/pengertian-use-case-a7e576e1b6bf>
- Anshari, M., Almunawar, M. N., Lim, S. A., & Al-Mudimigh, A. (2019). Customer relationship management and big data enabled: Personalization & customization of services. *Applied Computing and Informatics*, 15(2), 94–101. <https://doi.org/10.1016/j.aci.2018.05.004>
- Asikin, M. Z., Fadilah, M. O., Saputro, W. E., Aditia, O., & Ridzki, M. M. (2024). The Influence Of Digital Marketing On Competitive Advantage And Performance of Micro, Small And Medium Enterprises. *International Journal of Social Service and Research*, 4(03), 963–970. <https://doi.org/10.46799/ijssr.v4i03.749>
- Athirah Imran, N., Asdar, M., & Muis, M. (2022). the Effect of Customer Relationship Management (Crm) on Customer Loyalty and Customer Satisfaction At Saung Rindu Alam Restaurants in Gowa District South Sulawesi. *Scientium Management Review*, 1(2), 73–86.
- Bayraktar, M., & Algan, N. (2019). The Importance Of SMEs On World Economies. *International Conference on Eurasian Economies 2019*, June 2019, 56–61. <https://doi.org/10.36880/c11.02265>
- Benitez, J., Henseler, J., Castillo, A., & Schuberth, F. (2020). How to perform and report an impactful analysis using partial least squares: Guidelines for confirmatory and explanatory IS research. *Information and Management*, 57(2), 103168. <https://doi.org/10.1016/j.im.2019.05.003>
- Bin Khunin, L. K., & Al-Nsour, I. A. A.-F. (2024). Impact of Digital Advertising Strategies on the Competitive Advantage of SMEs in KSA. *European Journal of Business and Management Research*, 9(2), 91–98. <https://doi.org/10.24018/ejbmr.2024.9.2.2285>

- Danurdara, A. B., Kumalasari, D. A., & Muis, Z. Z. (2024). Digital Marketing Strategy To Increase Brand Awareness in Industry. *International Journal of Economic Literature (INJOLE)*, 2(3), 774–785.
- Dašić, D., Vučić, V., Turčinović, Ž., & Tošić, M. (2023). Digital Marketing - Marketing Opportunities and the Power of Digital Consumers. *Ekonomika Poljoprivrede*, 70(4), 1187–1199. <https://doi.org/10.59267/ekopolj23041187d>
- Desai, D. M. V. (2019). Digital Marketing: A Review. *International Journal of Trend in Scientific Research and Development, Special Is(Special Issue-FIIIPM2019)*, 196–200. <https://doi.org/10.31142/ijtsrd23100>
- Ezeugwa, B., Farid Talukder, M., Ruhul Amin, M., Iqbal Hossain, S., & Arslan, F. (2022). Minimum sample size estimation in SEM: Contrasting results for models using composites and factors. *Data Analysis Perspectives Journal*, 3(1), 1-7.
- Fauziah, R. D., Arisman, A., & Pauzy, D. M. (2022). The Effect of Product Innovation and Product Quality on Competitive Advantage. *Jurnal Fokus Manajemen*, 2(1), 966–978. <https://doi.org/10.37676/jfm.v2i1.2257>
- Gil-Gomez, H., Guerola-Navarro, V., Oltra-Badenes, R., & Lozano-Quilis, J. A. (2020). Customer relationship management: digital transformation and sustainable business model innovation. *Economic Research-Ekonomika Istrazivanja*, 33(1), 2733–2750. <https://doi.org/10.1080/1331677X.2019.1676283>
- Graciafernandy, M. A., Usriyono, E., & Istiyawari, L. (2024). Enhancing Marketing Performance of SMEs through Competitive Advantage. *Proceeding International Conference on Religion, Science and Education*, 3, 587–596.
- Gutiérrez-Broncano, S., Linuesa-Langreo, J., Rubio-Andrés, M., & Sastre-Castillo, M. Á. (2024). Can hybrid strategy improve SME performance? The role of innovation and adaptive capacity. *European Journal of Innovation Management*, 27(9), 173–197. <https://doi.org/10.1108/EJIM-07-2023-0566>
- Hakim, A. (2024). The Human Resource Development and Product Innovation of MSMEs in Kendari City. 12(4), 913–924. <https://doi.org/10.37641/jimkes.v12i4.2639>

- Handoyo, A. S. (2015). The effect of marketing innovation, market orientation, and social capital on competitive advantage and marketing performance: A study in MSMEs of embroidery Central Java Province. *Journal of Economics, Business & Accountancy Ventura*, 18(3), 351. <https://doi.org/10.14414/jebav.v18i3.506>
- Hat, N. D., Tan, K. L., Ngoc Vi, N. L., Phu, N. A., & Ting, H. (2024). The Influence of Customer Relationship Management in Enhancing Hospitality Business Performance: The Conditional Mediation of Digital Marketing Capabilities. *International Journal of Hospitality and Tourism Administration*, 00(00), 1-27. <https://doi.org/10.1080/15256480.2024.2346142>
- Henseler, J. (2017). ADANCO 2.0.1 User Manual. February, 1-53.
- Henseler, J., Hubona, G., & Ray, P. A. (2016). Using PLS path modeling in new technology research: Updated guidelines. *Industrial Management and Data Systems*, 116(1), 2-20. <https://doi.org/10.1108/IMDS-09-2015-0382>
- Jusuf, D. I. (2022). Product Innovation: Maintaining Competitiveness in a Competitive Market. *Jurnal Ekonomi*, 11(02), 2022. <http://ejournal.seaninstitute.or.id/index.php/Ekonomi>
- Kuncoro, W., & Suriani, W. O. (2018). Achieving sustainable competitive advantage through product innovation and market driving. *Asia Pacific Management Review*, 23(3), 186-192. <https://doi.org/10.1016/j.apmrv.2017.07.006>
- Musonafa, M. A., Sumiati, S., & Djazuli, A. (2022). The Effect of Customer Relationship Management on Marketing Performance Mediated by Competitive Advantage and Innovation (Study on Area Managers of Pharmaceutical Companies in East Java during the COVID-19 Pandemic). *Asia Pacific Journal of Management and Education*, 5(2), 111-121. <https://doi.org/10.32535/apjme.v5i2.1642>
- Nadanyiova, M., Majerova, J., & Gajanova, L. (2021). Digital Marketing As a Source of Competitive Advantage: Case Study of Slovak Republic. *Marketing and Management of Innovations*, 2(4), 92-103. <https://doi.org/10.21272/mmi.2021.4-08.This>
- Nurfaizah, N., & Marsasi, E. G. (2024). Application Of Customer Relationship Management Through the Concept of Technology Adoption in the Broiler Jaya Broad Marketing Program. *Ekonika: Jurnal Ekonomi Universitas Kadiri*, 9(1), 1-23. <https://doi.org/10.30737/ekonika.v9i1.4862>

- Pramuki, N. M. W. A., & Kusumawati, N. P. A. (2021). The Influence of Product Innovation, Digital Marketing and Competitive Advantage in Improving the Marketing Performance of Small and Medium Industries in Bali. *Proceedings of the 2nd International Conference on Business and Management of Technology (ICONBMT 2020)*, 175, 248–254. <https://doi.org/10.2991/aebmr.k.210510.040>
- Purwanti, I., Lailyningsih, D. R. N., & Suyanto, U. Y. (2022). Digital Marketing Capability and MSMEs Performance: Understanding the Moderating Role of Environmental Dynamism. *Jurnal Manajemen Teori Dan Terapan | Journal of Theory and Applied Management*, 15(3), 433–448. <https://doi.org/10.20473/jmtt.v15i3.39238>
- Ralahallo, F. N., Tubalawony, J., Watumlawar, E., & Tabelessy, W. (2024). Implementasi Total Quality Manajemen (TQM) Sebagai Strategi Meningkatkan Keunggulan Bersaing Pada UMKM di Negeri Waai. *Abdimas Indonesian Journal*, 4(1), 187–194. <https://doi.org/10.59525/aij.v4i1.3>
- Reguia, C. (2014). Product Innovation And The Competitive Advantage. *European Scientific Journa*, 1(June), 140–157.
- Sopyan, A., Suryawan, R. F., Maianto, T., & Haryanto, A. (2018). CRM (Customer Relationship Management) Approach to Sustainability through Competitive Advantage. 1(1), 98–109.
- Sukaatmadjaa, I. P. G., Kerti, Y. N. N., Henny, R., Made, S., & Dharmanegarab, I. B. A. (2021). Competitive advantage to enhance internationalization and marketing performance woodcraft industry: A perspective of resource-based view theory. *Journal of Project Management*, 6, 45–56. <https://doi.org/10.37479/jsm.v6i1.22551>
- Tabelessy,, W., Sitaniapessy,, R. H., & Ralahallo, F. N. (2024). Digital Supply Chain Terhadap Kinerja Pemasaran Industri UKM di Kota Ambon. *Media Bina Ilmiah*, 18(7), 1947–1958.
- Tabelessy, W. (2024). Brand Love : Mediating Effect of the Relationship Between Social Media Marketing , Brand Loyalty and Brand Equity iPhone Brand Smartphone in Ambon City. *International Journal of Integrative Research (IJIR)*, 2(5), 439–452.
- Tabelessy, W., & Pattiruhu, J. R. (2024). Pelatihan WarpPLS: Aplikasi Alternatif Pengujian Hipotesis SEM-PLS. *Communnity Development Journal*, 5(2), 2723–2729.

- Tabelessy, W., Rehatta, P. N. R., & Saununu, S. (2022). Meningkatkan Pengetahuan Jiwa Kewirausahaan Bagi Kelompok Usaha Mekar Sari Di Desa Laha. *Community Development Journal: Jurnal Pengabdian Masyarakat*, 3(2), 589–594. <https://doi.org/10.31004/cdj.v3i2.4446>
- Tabelessy, W., & Turukay, E. (2024). Meningkatkan Kinerja Pemasaran UMKM Melalui Sosialisasi E-Market Orientation Supply Chain. *Jurnal Pengabdian Multidisiplin*, 4(2), 1–12.
- Tubalawony;, J., Pelupessy, M. M., Tabelessy, W., & Thenu, C. J. (2023). Peran E-Satisfaction dalam Memediasi Pengaruh E-Service Quality terhadap E-Loyalty pada Pengguna Aplikasi Blibli . Com. *Jurnal Pendidikan Tambusai*, 7(2), 4491–4498.
- Yasa, N. N. K., Ketut Giantari, I. G. A., Setini, M., & Rahmayanti, P. L. D. (2020). The role of competitive advantage in mediating the effect of promotional strategy on marketing performance. *Management Science Letters*, 10(12), 2845–2848. <https://doi.org/10.5267/j.msl.2020.4.024>
- Yunarti, Munizu, M., Arsyad, M., & Munir, A. R. (2024). Digital Marketing as a Powerful Tool to Improve MSMEs Performance (Issue Icame 2023). Atlantis Press International BV. https://doi.org/10.2991/978-94-6463-400-6_28