

Realtime Broiler Chicken Cage Control and Monitoring System

Juli Iriani¹, Nobert Sitorus², Gunoro^{3*}, Abdullah⁴, , Cholish⁵, Wahyudi⁶,
Michael Doanta Meliala⁷, Rani Dame Hasibuan⁸

^{1,2,3,4,5,7,8} Politeknik Negeri Medan

⁶ CV. Jiwa Karya

Corresponding Author: Gunoro gunoro@polmed.ac.id

ARTICLE INFO

Keywords: Broiler Chicken,
Realtime, Control,
Monitoring, Internet of
Things

Received : 20 March

Revised : 20 April

Accepted: 21 May

©2024 Iriani, Sitorus,
Gunoro, Abdullah, Cholish,
Wahyudi, Meliala, Hasibuan:
This is an open-access article
distributed under the terms
of the [Creative Commons
Atribusi 4.0 Internasional](https://creativecommons.org/licenses/by/4.0/).



ABSTRACT

Control and monitoring systems in poultry farm cages are very necessary, especially for broiler farmers because the harvest process from growth to ready to harvest takes 30 to 35 days with a weight per tail between 1.5-2.0 kg. Important variables that are prioritized in broiler cages, namely temperature, humidity and lighting as well as the availability of feed and drinks on time, determine the quality and quantity of the broiler harvest. The solution to these problems requires a system that can work automatically with real-time monitoring features so that important variables in the chicken coop can be really well maintained. This research uses a combination of DHT11 temperature and humidity sensors, proximity sensors as sensors to check the availability of water and feed in containers, LDR light sensors and GY-302 Lux sensors, Real Time Clock timer modules to organize scheduling the availability of drinking water and chicken feed. These sensors will provide data to the ESP32 controller to control outputs such as heating and cooling and valves for opening and closing the stock of drinking water and feed. This system has also been integrated with the Internet of Things so that the condition of the chicken coop can be flexibly monitored remotely using a Smartphone or laptop utilizing the internet network. Based on the tests that have been carried out, it proves that the system has worked well in maintaining important variables in the chicken coop and has been well integrated based on the Internet of Things.

INTRODUCTION

Nowadays, the poultry farming business is favored by many people because it is able to benefit from the economic sector. Broiler farming is one of the businesses that is easy to run and has a fairly high demand for results. Maintenance and placement of livestock cages are very necessary, especially for broiler farmers because the harvest process from growth and laying eggs takes 1.5 - 2 months. The maintenance and placement of broiler farm cages is influenced by the temperature and humidity of the surrounding environment, where if the temperature is low it causes chickens to be attacked by disease so that farmers have difficulty in regulating and monitoring the temperature and humidity of the chicken coop (Maryanti, Haryono, & Endaryanto, 2023). Another problem that often arises is that feeding and drinking to chickens is still done manually and must be adjusted to the age of the chicken so that farmers have to take a long time on the farm (Naser, Rumiyan, Susanti, & Shaffira, 2023).

In the era of digitalization, technological developments at this time really help people in applying electronic components to facilitate work by utilizing microcontrollers and the Internet of Things (IoT) which are applied in various fields, especially in the field of animal husbandry. The microcontroller is in charge of controlling and monitoring which is connected to sensors and other electronic components. Microcontroller and Internet of Things (IoT) a control system that can communicate between each other via the internet network. With an internet connection, it is able to use and control this technology wherever and whenever it is so that it is very useful for broiler farmers to make it easier to monitor the temperature and humidity conditions of the environment around the cage remotely from the location of the farm (Fitriasari, Zuhrie, Rusimanto, & Kholis, 2020).

Based on the above background, researchers see the need to implement a control and monitoring system for broiler farms based on the Internet of Things (IoT) to make it easier to monitor temperature, humidity and monitor feed and drinking stocks and lighting on broiler farms based on the Internet of Things (IoT) as remote realtime control and monitoring.

LITERATURE REVIEW

The control and monitoring system in the maintenance and placement of poultry farm cages is very necessary, the maintenance and placement of broiler farm cages is influenced by the temperature and humidity of the surrounding environment, where if the temperature is not appropriate it causes the chicken to be attacked by disease so that farmers have difficulty in regulating and monitoring the temperature and humidity of the chicken coop. Another problem that often arises is monitoring the availability of feed and water for chickens and feeding chickens is still done manually so that farmers have to take a long time on the farm and tend not to be on time (Ramadiani, Widada, Widiastuti, & Jundillah, 2021).

Previous research related to this research only focuses on one problem in the implementation system of the control and monitoring system of broiler farms based on the Internet of Things, while many factors are very important in

broiler farming, namely temperature and humidity of the drum, lighting, setting feed and drinks for broilers, all of which must be properly regulated, if one of these factors is not appropriate or something is not right, it will become a problem in the broiler farming system. Previous studies related to the research conducted can be seen in table 1 below.

Table 1. Previous Research Relevant to This Research

No.	Researcher	Title	Result
1	Masriwilaga et al, 2019	<i>Sistem Monitoring Peternakan Ayam Broiler Berbasis Internet of Things</i>	In this study describes the use of the Internet of Things in a gas detection system in a chicken coop in the form of ammonia and methane gas levels (Masriwilaga, Jabar, Subagja, & Septiana, 2019).
2	Dewanto et al, 2019	<i>Development of an Automatic Broiler Feeding System using PLC and HMI for Closed House System</i>	This system has several advantages, including temperature and humidity that must be maintained for broilers. In addition to temperature and humidity, the broiler feeding system also needs to be controlled because it will improve the quality of broilers (Dewanto, Munadi, & Tauviquirrahman, 2019).
3	Fitriasari et al, 2021	<i>Perancangan Sistem Monitoring dan Controlling Kandang Ayam Berbasis Internet of Things</i>	This research discusses monitoring temperature and humidity in broiler cages using the Internet of Things (Fitriasari et al., 2020).

A. Broiler Chicken

Broiler chickens are referred to as broilers which are chickens with fast breeding so that they can produce meat within 1 - 2 months. Broiler chickens have an important role as a source of protein in society, so high productivity is needed in terms of quantity, quality and efficiency in developing broiler farming businesses without using chemicals. In producing quality productivity, it is necessary to select broiler seeds with the characteristics of having good health by looking at active movement, round body and clean limbs. In addition to these characteristics, the conditions where the chickens breed must also be considered by looking at several factors such as the position / model of the cage, air circulation, feed and drink to be given and the air temperature in the cage (Dewantari, Suparta, & Putri, 2023).

B. Controller System

The control system to drive all sensor work uses Arduino as an electronic device that functions like a microcontroller and is open source (Manurung & Haris, 2022). Arduino has a processor from the Atmel AVR family. Arduino has software with a specific programming language. The arduino board has the ability to read digital - analog data input and output digital - analog data. Arduino programming is supported by IDE (Integrated Development Environment) making it a fun and widely used programming. Many types of arduino boards are available on the market with designs tailored to various applications. The arduino board is a printed circuit board (PCB) designed to use a microcontroller chip and other inputs and outputs. the board has many other electronic components needed for the microcontroller to function or to expand its capabilities (Balqis & Abdullah, 2021).

C. Sensors

DHT11 is a sensor that has the function of being able to measure air temperature and humidity (Putri & Abdullah, 2021). This sensor is very easy to connect with Arduino. This sensor is equipped with a special NTC to measure temperature and an 8 bit microcontroller to output temperature and humidity values via serial communication. The sensor is also factory calibrated and hence easy to interface with other microcontrollers. The working principle of the DHT11 sensor is to measure the temperature where on the surface of this sensor there is a thermistor which is a variable resistor with resistance that changes with temperature changes. While the way the DHT11 sensor works as a humidity measure is to detect water vapor by measuring the electrical resistance between two electrodes (Ramadiani et al., 2021).

Proximity sensors or distance sensors are sensors that have a function to detect changes in distance on an object without physical contact. The workings of this sensor use electromagnetic radiation in the process so as to make this sensor able to detect the presence of objects or their conditions even without physical contact by setting a nominal interval so as to inform the object to be detected (Dewanto et al., 2019).

The water level sensor is a sensor that controls automatically in backing up the availability of water if there is a problem with the water supply such as a

power outage. The way this sensor works is through reading the resistance value produced by water that hits the slab line on the sensor (Hendrikus, Setyaningsih, & Suhardi, 2022).

Light Dependent Resistor (LDR) is a resistor type sensor whose resistance value depends on the light intensity it receives. The lower the light intensity received, the higher the LDR resistance value. Conversely, the higher the light intensity received by the LDR, the lower the LDR resistance value. In other words, the Light Dependent Resistor can conduct electric current when it receives a certain amount of light intensity (bright conditions) and inhibit electric current in dark conditions (Simbolon, Saragih, & Waluyo, 2022).

METHODOLOGY

In the research, the implementation of a control and monitoring system for broiler farms based on the Internet of Things combines the hardware part and the software part, where the hardware consists of mechanical design and electronic design needs. While the software part consists of programming needs such as sensor work algorithms and application feature needs from the monitoring process carried out with Internet of Things-based technology.

A. Hardware Design

Hardware development consists of two core elements, namely mechanical system design and electronic system design. The mechanical design focuses on the physical aspects of the system, while the electronic design includes various electronic components such as controllers, sensors, and other electronic modules. The mechanical design of the system can be seen in Figure 1, while Figure 2 shows the block diagram for the overall hardware design.

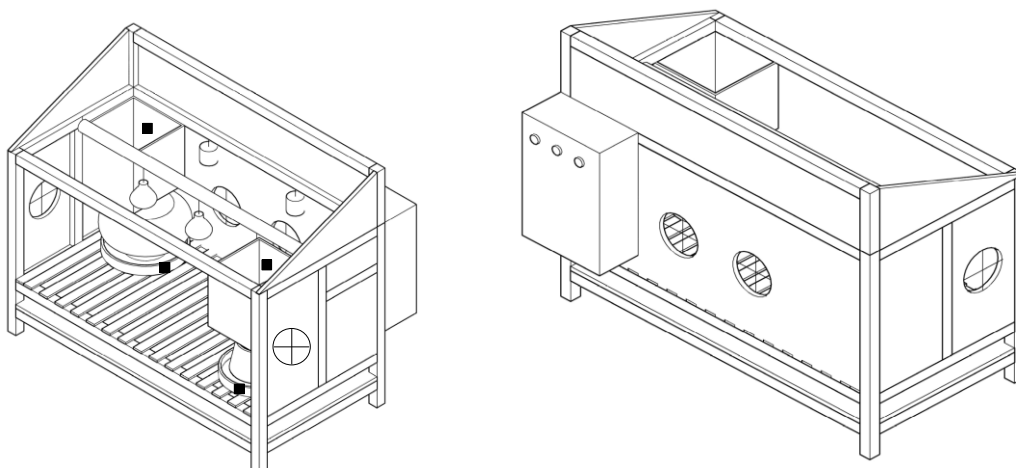

Figure 1. The Mechanical Design of System

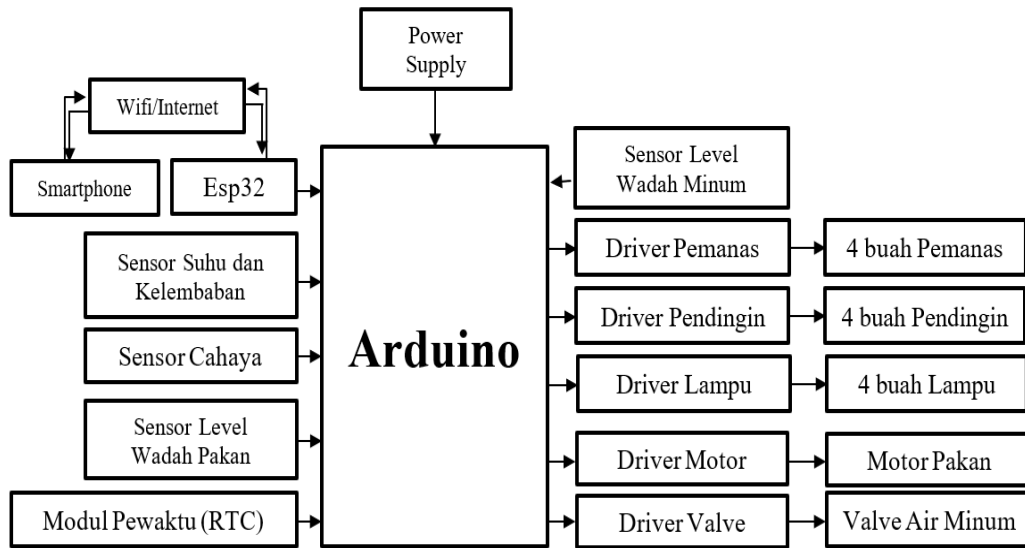

Figure 2. The Block Diagram for The Overall Hardware Design

In the mechanical design, various main materials such as hollow iron, plate iron, aluminum plate are used to ensure strength and ease of formation according to the needs of the system.

In the overall system design picture above, there is a main controller in the form of an arduino that will be connected to the entire circuit and also connected to the ESP 32 via the internet. In addition to the arduino, the power supply as a supplier to the entire system so that the entire circuit can work. The temperature and humidity sensor serves to check the temperature and humidity in the broiler cage, when the temperature in the chicken coop is hot (not according to the temperature of broilers) then the fan driver will work to activate the number of fans as needed to cool the temperature in the chicken coop and vice versa when the temperature in the chicken coop is cold (not according to the temperature of broilers) then the heating lamp driver will work to activate the number of lights as needed to heat the temperature in the chicken coop, the light sensor regulates the light intensity of the chicken coop, from this sensor it will be connected to the lamp driver to turn on the lighting lamp. Then the feed and drink availability sensor regulates and supplies food and drinks in the chicken coop where the availability of food will be connected to the motor driver while the availability of drinks will be connected to the water pump driver to regulate the accuracy of feeding and drinking. The timer module is used to regulate the timeliness of feeding and drinking to broiler chickens.

This research model is a system that focuses on controlling and monitoring temperature, humidity, lighting, availability and regulation of feed and drinking on broiler farms. The method used is experimental and analyzes the deviation of the entire circuit. This system has also integrated the Internet of Things as a remote realtime control and monitoring that can be monitored

using only a Smartphone in which there is an application to support system work.

B. Software Design

Software development is done by programming using the C language through the Arduino IDE software, which functions as the main application for managing the system controller, including the control and monitoring process. In addition, the Blynk application is also used as an Internet of Things interface design. An overview of this software display can be seen in Figure 3 below:

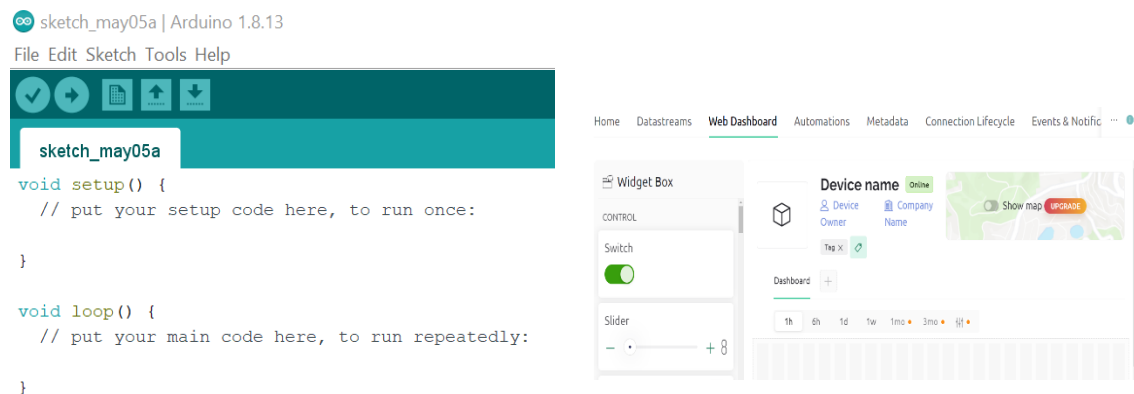

Figure 3. The Display of This Software Design

RESEARCH RESULT

The results and discussion on the implementation of the Internet of Things-based broiler farm control and monitoring system consist of three tests, namely testing the results of the temperature and humidity sensor readings, testing the light sensor, testing the Real Time Clock against the limit sensor (level) on the chicken feed and drinking container, testing the entire Internet of Things integrated system. The following are the results of the system design in Figure 4.



Figure 4. Overall Result Display of The System Design

A. Testing the Results of Temperature and Humidity Sensor Readings

In this test shows the results of reading the two temperature and humidity sensors using the DHT-11, this DHT-11 sensor reads the temperature of the chicken coop environment, this sensor has analog data that will be processed by the Arduino controller, in this test also shows the results of reading the reference temperature and humidity sensor using a hygrometer in the placement position of each DHT-11 sensor that has been designed, with the aim of getting data on the accuracy of temperature and humidity readings in broiler cages, from the results of this DHT-11 sensor reading which will determine the heating device (incandescent lamp) and cooling device (fan) in the chicken coop.

Table 2. Testing DHT-11 Sensor Readings with Hygrometer Readings

No.	Hygrometer		DHT-11		Persen Error (%)	
	Temperature (°C)	Humidity (%)	Temperature (°C)	Humidity (%)	Temperature (°C)	Humidity (%)
1	27,5	66	28,23	68	2,65	3,03
2	28,9	69	29,51	72	2,11	4,35
3	30,3	72	29,73	74	1,88	2,78
4	32,8	74	33,65	76	2,59	2,70
5	33,2	83	33,77	85	1,71	2,41
Average					2,19	3,05

This DHT-11 test shows the percent (%) error of the DHT-11 sensor reading between the system design and the Hygrometer reference tool so as to determine the level of accuracy of the DHT-11 sensor reading used in the system.

The percent (%) error formula used is as follows:

$$\%Error := \frac{Reference\ Reading - System\ Sensor\ Readings}{Reference\ Reading} \times 100\%$$

From Table 2 above, it can be seen that the percentage error value between the system sensor reading and the reference reading is quite low, it can be seen that the largest percentage error value is 2.65% with an average of 2.19 for temperature and 4.35 % with an average of 3.05 for humidity, from Table 2 above the DHT-11 sensor work has worked well.

B. Light Sensor Reading Results

In this test shows the results of reading the two light sensors using LDR sensors, this LDR sensor reads the light intensity of the chicken coop environment, this sensor has analog data that will be processed by the Arduino controller, in this test also shows the results of reading the LDR Light sensor

that has been designed, with the aim of getting light reading data in the broiler cage, from the results of reading this LDR sensor which will determine the number of active lights in the chicken coop.

Table 3. Testing the LDR Sensor Reading Results

Time (Western Indonesian Time)	LDR Sensor Analog Voltage		Light Status
	LDR_Sensor 1 (Volt)	LDR_Sensor 2 (Volt)	
10.00	0,27	0,23	Bright
11.00	0,29	0,25	Bright
17.00	3,97	4,21	Dim
19.00	4,67	4,73	Dark
20.00	4,71	4,76	Dark

From table 3 above, it can be seen that the value of the difference in the value of the LDR sensor when it is light and dark, when it is light the LDR sensor outputs a small voltage output while when it is light the LDR sensor outputs almost maximum voltage where the LDR output voltage range is 0 - 5 Volts, from Table 3 above the LDR sensor work has worked well.

C. Testing Timing Results against feed and drinking limit sensors

This test shows the work of setting the time to activate the work of the drive motor to open the feed container and activate the valve to open the flow of chicken drinking water, to stop the work of both the drive motor and the valve is done by the level sensor that has been installed on the container both the feed container and the drink container. If the time to drive the feed container motor is set at: 08.00 WIB and if the time to activate the water valve is set at: 09.00 WIB, then the timing work can be seen in the following table.

Table 4. System testing based on time settings

No.	Time Setting (Western Indonesian Time)	Feed Motor Condition	Drinking Water Valve Condition	Feed Limit Sensor Status	Status of Drinking Water Limit Sensor	Feed Motor Condition	Drinking Water Valve Condition
1	07.00	Off	Off	Off	Off	Off	Off
2	08.00	On	-	Off	-	On	-
3	08.00	On	-	On	-	Off	-
4	09.00	-	On	-	Off	-	On
5	09.00	-	On	-	On	-	Off
6	10.00	Off	Off	Off	Off	Off	Off

From table 4, it can be seen how the time setting works on the feed limit sensor and drinking water limit sensor on the chicken drum, where when the

time is set for the feed will activate the drive motor to open the feed container, as well as if when the time is set to activate the drinking water valve, the drinking water will flow, but to deactivate both the drive motor and valve waiting for detection from the limit sensor both feed and drinking water containers.

D. Testing the Internet of Things integrated monitoring and control system

The Internet of Things integrated monitoring and control system test shows how the concept of remote monitoring and control utilizing IoT technology can be carried out on broiler farming systems using the Blynk application. Some of these tests can be seen in Figure 5.

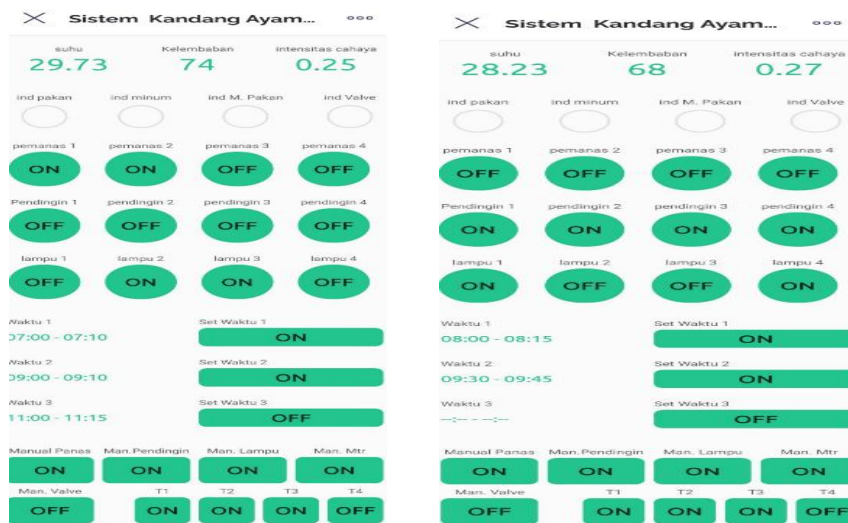

Figure 5. Testing The Internet of Things Integrated Monitoring and Control System

From the tests carried out, all monitoring data, both temperature, humidity, light intensity and indicators of feed, drinking, feed drive motors and valves for opening and closing drinking water and remote control of both 4 heaters, 4 coolers, 4 lighting and 3 time settings, both monitoring data and control devices can be monitored and controlled properly in one Blynk application that has been integrated with the Internet of Things.

DISCUSSION

Important variables that are prioritized in broiler cages are temperature, humidity and lighting as well as the availability of feed and drinks on time to determine the quality and quantity of the harvest of broiler chickens. The use of a combination of DHT11 temperature and humidity sensors, proximity sensors as sensors to check the availability of water and feed in containers, LDR light sensors and GY-302 Lux sensors, Real Time Clock timer modules to regulate the scheduling of the availability of drinking water and chicken feed with ESP controllers can be a solution, it can only be further conceptualized for more

complex features and focus more on the efficient use of electrical energy in this chicken coop.

CONCLUSIONS AND RECOMMENDATIONS

The conclusions of this research, namely the results of testing the implementation of the Internet of Things-based broiler farm control and monitoring system that has been successfully carried out and works well through three types of variables that are controlled and monitored, namely temperature and humidity, light and time with heating output in the form of incandescent lamps, cooling in the form of fans. All inputs and outputs used in the system have been well integrated with work functions according to the given algorithm coupled with Internet of Thing-based features so that all inputs and outputs can be controlled and monitored remotely only through a laptop or Smartphon flexibly.

ADVANCED RESEARCH

Better designs, more sensors and better control algorithms are needed to create chicken coops with more complex features and more focus on efficient use of electrical energy.

ACKNOWLEDGMENT

The author would like to thank the Medan State Polytechnic for the funding provided through Contract: B/255/PL5/PT.01.05/2023 which comes from DIPA POLMED funds for 2023.

REFERENCES

- Balqis, R., & Abdullah, A. (2021). APPLICATION OF AUTOMATION PLANTING SYSTEM AT GREEN HOUSE IN IMPROVING PLANT QUALITY. *Fisitek: Jurnal Ilmu Fisika dan Teknologi*, 4(2), 27-35.
- Dewantari, R. Y., Suparta, N., & Putri, B. R. T. (2023). Analysis of supply and demand of broiler chicken meat in Bali province. *Agricultural Socio-Economics Journal*, 23(1), 1-9.
- Dewanto, P., Munadi, M., & Tauviqirrahman, M. (2019). Development of an automatic broiler feeding system using PLC and HMI for closed house system. *American Scientific Research Journal for Engineering, Technology, and Sciences (ASRJETS)*, 58(1), 139-149.
- Fitriasari, F., Zuhrie, M. S., Rusimamto, P. W., & Kholis, N. (2020). Perancangan sistem monitoring dan controlling kandang ayam berbasis internet of things. *Indonesian journal of engineering and technology (inajet)*, 3(1), 17-27.
- Hendrikus, H., Setyaningsih, F. A., & Suhardi, S. (2022). Sistem Pengontrolan Dan Monitoring Pada Kandang Ayam Broiler Berbasis Internet Of Things (Iot). *Jurnal Informatika dan Rekayasa Perangkat Lunak*, 3(1), 117-128.
- Manurung, A. A., & Haris, M. (2022). PROTOTYPE SISTEM KONTROL KOLAM IKAN NILA BERBASIS OUTSEAL PLC TERINTEGRASI

- INTERNET OF THINGS. *Prosiding Konferensi Nasional Social & Engineering Polmed (KONSEP)*, 3(1), 692-702.
- Maryanti, E. V., Haryono, D., & Endaryanto, T. (2023). Broiler Chicken Livestock Business Development Strategy in South Lampung Regency. *Jurnal Ilmiah Peternakan Terpadu*, 11(3), 159-175.
- Masriwilaga, A. A., Jabar, T. A., Subagja, A., & Septiana, S. (2019). Sistem monitoring peternakan ayam broiler berbasis internet of things. *Telekontran: Jurnal Ilmiah Telekomunikasi, Kendali dan Elektronika Terapan*, 7(1), 1-13.
- Naser, N. M., Rumiyan, T., Susanti, S., & Shaffira, M. R. (2023). Broiler Cage Management in Karya Mandiri Farm Coop, Trimulyo Village, Tegineneng District, Pesawaran Regency. *Jurnal Agribisnis Peternakan (JINAK)*, 1(1), 1-5.
- Putri, S. D., & Abdullah, A. (2021). APPLICATION OF AUTOMATION HYDROPONIC PLANTING SYSTEM BASED ON ACIDITY, NUTRIENT CONCENTRATION AND LIGHTING. *Fisitek: Jurnal Ilmu Fisika dan Teknologi*, 5(1), 13-20.
- Ramadani, R., Widada, D., Widiastuti, M., & Jundillah, M. (2021). Temperature and humidity control system for broiler chicken coops. *Indonesian Journal of Electrical Engineering and Computer Science*, 22(3), 1327-1333.
- Simbolon, H., Saragih, Y., & Waluyo, P. (2022). Implementasi Internet Of Things (Iot) Dalam Sistem Pemantauan Serta Kontrol Suhu Dan Pakan Ayam Petelur Kandang Tertutup. *Jurnal Teknovasi*, 9(02), 89-104.