

Evaluating the Seismic Resilience of Newly Constructed Concrete Building in Zinda Jan District After the Devastating October 2023 Earthquake in Herat, Afghanistan

Arif Alkozay¹, Rahimullah Stankzai², Amanollah Faqiri³
Herat University Afganistan

Corresponding Author: Arif Alkozay : arif.alko123@gmail.com

ARTICLE INFO

Keywords: Zinda Jan Earthquake, Etabs, Push-Over Analysis, Plastic Hinges

Received : 20, April

Revised : 22, May

Accepted: 25, June

©2024 Alkozay, Stanajzai, Faqiri (s):
This is an open-access article distributed under the terms of the [Creative Commons Atribusi 4.0 Internasional](https://creativecommons.org/licenses/by/4.0/).



ABSTRACT

This study aims to evaluate the impact of the October 2023 earthquake on the Zinda Jan district, focusing on the structural integrity of more than 2000 newly constructed buildings situated near fault lines. The specific objective is to identify any vulnerabilities in the design of these structures. Advanced computer analyses, including Linear and Non-linear (Push-over analysis) assessments using Etabs software, were employed to investigate the structural performance of the buildings. The analysis revealed significant insights into the structural integrity of the new constructions. It was observed that certain central columns exhibited inadequate strength, thereby posing a considerable risk of failure during seismic events. This vulnerability primarily stems from a disparity in strength between columns and beams, with the latter being stronger. This research contributes to the field by emphasizing the critical role of meticulous design and analysis in safeguarding buildings located in earthquake-prone regions.

INTRODUCTION

Over time, natural disasters, particularly earthquakes, have resulted in significant human casualties. An earthquake occurs when the earth's surface shakes due to a sudden release of energy in the lithosphere, creating seismic waves (Wikipedia, 2019). These waves can cause buildings to sway and increase stress on their structural components. If buildings are not adequately designed to withstand earthquakes, they may collapse, resulting in loss of life. The February 2023 earthquake in Turkey-Syria serves as a poignant example, where numerous buildings collapsed due to non-compliance with building codes, leaving over 2 million survivors homeless and in need of humanitarian aid (Nc state University, 2023). While it is impossible to prevent earthquakes entirely, one effective approach to minimizing the resulting loss of life is the construction of standardized buildings designed to withstand severe seismic waves (USGS, 2015). An illustrative instance is the Turkey-Syria earthquake, where deficiencies in building design resulted in significant human casualties that are challenging to remedy. Following this tragedy, the Turkish government resolved to construct new buildings that adhere to seismic codes, aiming to instill a sense of security among residents in case of future earthquakes. However, a prevalent issue in Afghanistan is the construction of buildings that do not meet established codes and standards for earthquake resilience. Consequently, uncertainty looms over the ability of our structures to withstand future seismic events (Alkozay, 2023). This concern is exacerbated by the widespread use of mud and brick construction, particularly in rural areas, rendering buildings highly susceptible to seismic impact and collapse fault, raising the specter of another high-magnitude earthquake.

Earthquakes in the western part of Afghanistan are primarily attributed to the Harirud Fault and the Band-e Turkestan Fault. However, these fault lines have remained inactive for many years, and the western part of the country has not experienced any major earthquakes in recent decades. Given that the Zinda Jan district is situated in the central part of Herat Province, where the Harirud Fault line passes through, the seismic risk is elevated if both the Harirud and Band-e-Turkestan Faults become active (Wikipedia, 2023). The devastating earthquake on October 7, 2023, with a magnitude of 6.3 and its epicenter in the Zinda Jan district, where the majority of buildings were constructed from brick and mud, caught many off guard (Wikipedia, 2023). In the aftermath, numerous buildings were completely destroyed, resulting in devastating losses for the residents of Zinda Jan in Herat Province. Fortunately, various non-governmental organizations and charitable foundations stepped in to address the crisis, initiating the construction of more than 2000 single-story houses for displaced residents. These new structures were built using concrete reinforcement, with

nearly 90 percent of them completed at the time of writing. Despite the progress in reconstruction, concerns have emerged regarding the structural integrity of these new buildings. Reports have suggested that they may not have been adequately designed to withstand future earthquakes, leading to reservations among residents about occupying them. Engineers have also highlighted the challenges posed by constructing buildings on fault lines like those in Zinda Jan. While some engineer express concerns about the adequacy of column and beam cross-sections, suggesting they may not withstand earthquakes of magnitude 7 or higher, others argue that the one-floor design ensures sufficient resilience even to higher-magnitude earthquakes without sustaining damage. We consulted several engineers from the municipality who were involved in the design process, and they indicated that the buildings were not designed using software but rather based on recommended cross-sections and rebar percentages for beams and columns.

Other engineers expressed concerns about weak columns and inadequate transverse reinforcement, suggesting a potential risk of column collapse during earthquakes. This disparity among engineers prompted the need for further research to redesign the current structures and assess their resilience to various degrees of earthquake intensity. This research aims to answer the critical question of whether the newly constructed buildings can withstand earthquakes of a magnitude similar to the previous 6.3 event and if they were designed according to the standards outlined in the USGS report for the Herat province. This assessment is crucial for instilling confidence among the residents of Zinda Jan in their new buildings and for informing structural designers and authorities about any necessary adjustments. The evaluation will employ advanced structural analysis techniques, including the use of Etabs software and assessments through Equivalent Force and Push-over (non-linear static analysis). While a push-over analysis may not be strictly necessary, conducting additional analyses is essential to ensure the accuracy and reliability of the study results and to identify any weak components within the structure during earthquakes, given their significant implications for the safety of the residents of Zinda Jan.

METHODOLOGY

This study employed a quantitative approach to redesign an existing structure that had already been constructed, utilizing the sophisticated software ETABS, version 21. Initially, the drawing data of the building, including reinforcement details and cross-sectional details of structural drawings, was obtained from the municipality. Subsequently, the building was modeled in ETABS software, with column dimensions of 30x30 centimeters, beam

dimensions of 45x30 centimeters, and a 15-centimeter slab thickness as shown in figure 3 and 4. Then necessary reinforcement, material, and concrete grade were assigned to members according to the structural drawings, as illustrated in Table 1. Following the modeling and assignment phase, a total of 21 load combinations were created, comprising 5 gravity-type loads and the remainder as lateral-type loads. Figure 6 shows the axing plan of the structure. The walls positioned beneath the beams were modeled as infill walls due to their significant effect on the result of the analysis. Subsequently, a Rho factor of 1 was assigned to the structure. Another important factor that was utilized in design, was Sds for considering vertical effect of seismic forces. The influence of these factors is reflected in the load combinations, with the Rho factor increasing earthquake loads in lateral-type combinations by a factor of 1, and Sds affecting gravity loads in lateral-type combinations. The study primarily focuses on two types of analysis. Firstly, it employs the Equivalent Lateral Force procedure, where inertial forces are treated as static forces (Di Julio, 2001). These forces are distributed throughout the structure's height to analyze its behavior. Secondly, a push-over analysis is utilized to assess the building's response during earthquakes. In this analysis, the load is gradually increased until failure occurs (Themelis, 2008). The use of push-over analysis is particularly beneficial when a structure exhibits deficiencies in its ability to withstand seismic forces (Leslie, 2013). Such deficiencies may stem from the absence of seismic design considerations during construction or from the structure's inadequacy in meeting seismic resistance requirements due to later upgrades in seismic codes (Leslie, 2013).

The application of push-over analysis in this study aligns perfectly with its purpose, which is to assess the need for retrofitting in specific areas such as modifications to column and beam cross-sections to withstand the specific earthquake under consideration. The study employed two distinct procedures to simulate different types of earthquakes. Initially, the simulation involved assessing ground motion probabilities using Hazard maps designated for cities in Afghanistan by USGS, considering both a 2 percent probability of exceedance and a 10 percent probability of exceedance. In the former case, Ss and S1 values of 62% and 24%, respectively, with a probability of exceedance of 2% over 50 years, were extracted from the Preliminary Earthquake Hazard Map of Afghanistan (Boyd & Mueller, 2007), as displayed in figure 1. These values are standard requirements for building design across Afghanistan. Conversely, in the second simulation, Ss and S1 were determined as 15% and 4%, respectively, from figure 1. Additionally, we considered the vertical effect of the earthquake in conjunction with other types of loads, in accordance with ASCE7-16, as

individuals reported severe vertical motion during the October 2023 earthquake. Incorporation of the vertical effect of load combinations was addressed in the design preferences section, where an Sds value of 1.05 was specified. Although it was not directly included in the load combinations, the program calculated its effect within the load combinations. For the push-over analysis, we initially created two types of non-linear static load cases. The first type comprised 1.1 times the sum of dead loads (D) and 0.25 times the live loads (L), while the second type consisted of 1.1 times 0.9 times the dead loads (D). Subsequently, four lateral non-linear static load cases were generated for each of these two types, with two in the X direction and two in the Y direction. Following the creation of non-linear static load cases, hinges were assigned to both beams and columns. Hinge specifications were based on table 6-7 and 7-8 of FEMA-356, with M3 degree of freedom for beams and P-M2-M3 for columns as shown in figure 4. After the analysis, the structure was evaluated to identify weak members and to assess its behavior with respect to each axis.

City	Lat.	Long.	2%		10%		PGA	0.2 sec	1.0 sec	0.2 sec	1.0 sec	0.0 sec
			Probability of exceedance in 50 years									
			PGA (%)	0.2 sec	1.0 sec	PGA						
Kabul	34.53	69.17	48	113	53	25	57	22	22			
Mazar-e Sharif	36.70	67.10	33	78	22	16	37	11	11			
Herat	34.35	62.18	28	62	24	7	15	4	4			
Kandahar	31.61	65.69	13	30	16	7	16	8	8			

Figure 1. Probabilistic ground motion for Afghanistan. Source: (USGS)

Structure specification details		
NO	NAME	INFORMATION
1	Structure System	Intermediate Concrete Moment Resistance Frame
2	Number of Floor	1 Floor
3	Full Area	11.7 X 5.9
4	Column Section	30cm x 30cm
5	Beam Section	45cm x 30 cm
6	Concrete Strength	25MP
7	Minimum Rebar Yield Strength	420MP
8	Ground Beam section	50cm x 30 cm
9	Ground Beam Reinforcement	6 N 14
10	Column Reinforcement	6 N 16
11	Beam Reinforcement	6 N 14
15	Soil type	D
16	Slab thickness	15mm

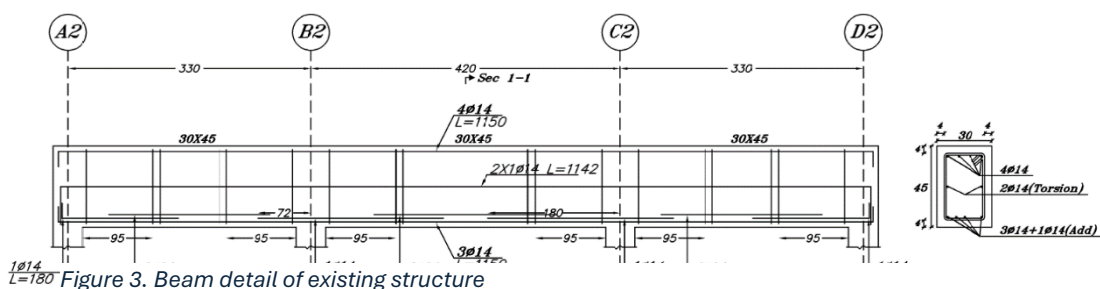

Figure 3. Beam detail of existing structure

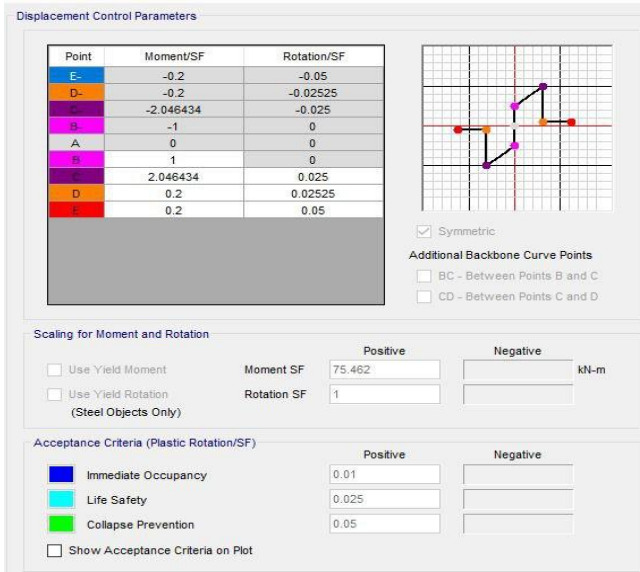

Figure 5. Assigned hinges properties according to FEMA-356

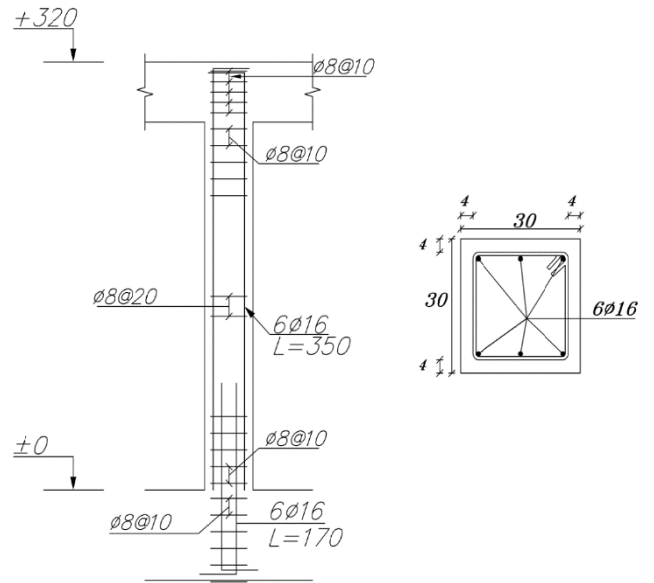

Figure 4. Column detail of existing structure

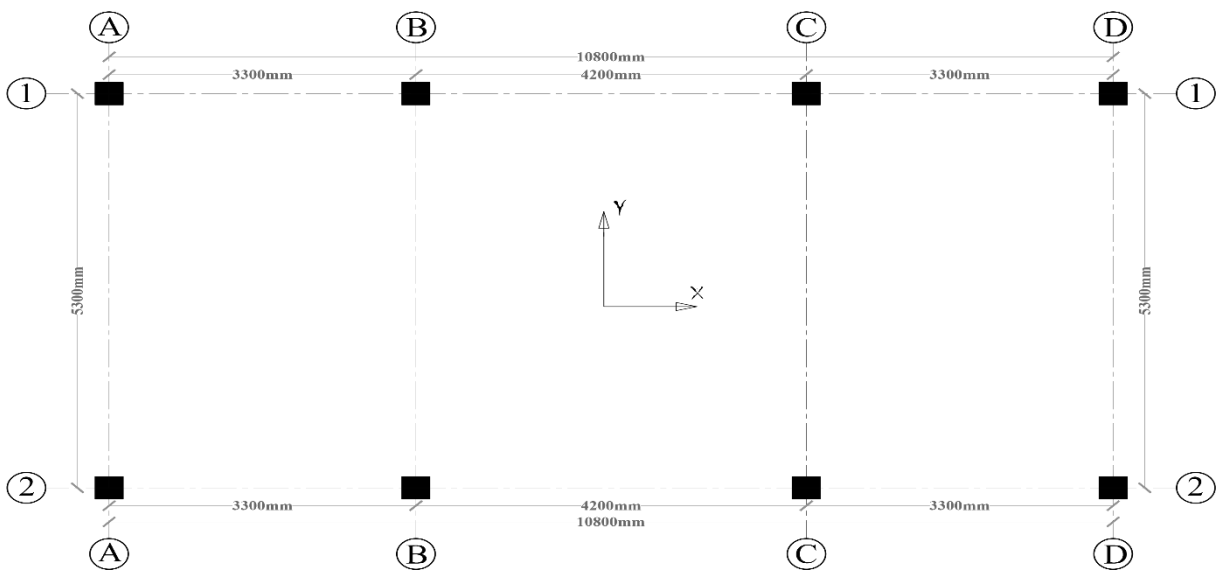

Figure 6. Shows axing plan of the structure

RESULT AND DISCUSSION

The analysis of the building based on the spectrum acceleration outlined in figure 1 for Herat province for 2 percent probability of exceedance indicates that four central columns lack sufficient strength to withstand the ground shaking specified by the earthquake hazard map. Figure 7 illustrates the failure of these columns under two types of load combinations. The first type, lateral load combination, attributed to the seismic severity of the 2 percent probability of exceedance earthquake, while the second type, gravity load combination (Load Combination 5), also contributed to the failure. In the lateral load combination scenario, the capacity ratio is 1.067, as depicted in Figure 7. Additionally, for the gravity load combination, this ratio is 1.022. These findings highlight that the columns not only fail to withstand the specified earthquake conditions for Herat province but also struggle to withstand gravity load combinations. Consequently, it is evident that the current dimensions of the columns, at 30*30cm, are inadequate and necessitate augmentation. The observation that the columns fail under the 2 percent probability earthquake solely from one lateral load combination is primarily attributed to the presence of walls modeled beneath the beams, significantly enhancing the lateral stiffness of the structure. Table 2 illustrates the base shear force corresponding to a 2-percent probability of exceeding.

Output Case	Case Type	FX	FY	FZ	MX	MY	MZ
Ex	LinStatic	-109	0	0	0	-391.1	287.74
Ey	LinStatic	0	-109	0	391.46	0	-586.3

Table 2. Shows the base shear forces for 2- percent probability of exceedance

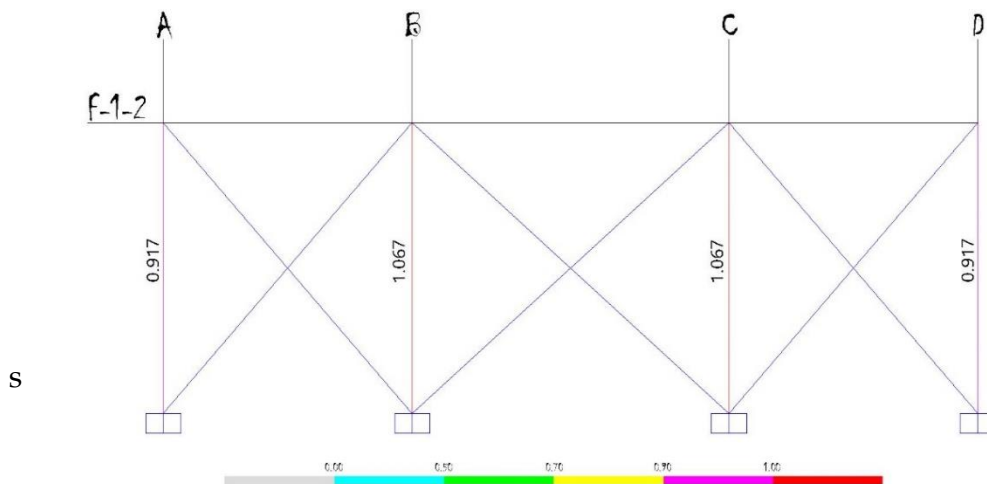

Figure 7. Shows the result of analysis for 2-percent probability of exceedance.

The findings for the 10 percent probability of exceedance reveal a different scenario. Due to the reduced severity of the earthquake, none of the columns fail under the lateral load combination. However, under the gravity load combination, depicted in Figure 8, the columns become overloaded with a capacity ratio of 1.022. This suggests that the columns possess sufficient strength to withstand a 10 percent earthquake. Nonetheless, the failure under the gravity load combination signals the need for further reinforcement by increasing their dimensions to enhance their strength.

Case Type	FX	FY	FZ	MX	MY	MZ
LinStatic	-32.2325	0	0	0	-116.1006	85.4161
LinStatic	0	-32.2325	0	116.206	0	-174.0555

Table 3. Shows the base shear forces for 10- percent probability of exceedance

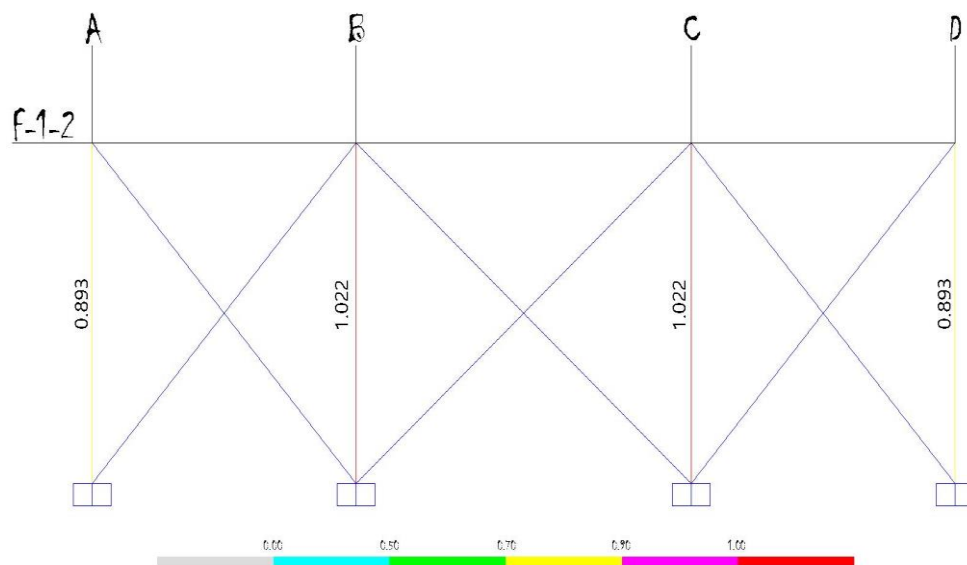

Figure 8. Shows the result of analysis for 10-percent probability of exceedance.

The push-over analysis conducted in the X direction, with a target displacement of 25mm, reveals significant findings. Initially, plastic hinges form at the tops of the four central columns, as depicted in Figure 9. As the load intensifies, these plastic hinges extend towards the base of the columns, as illustrated in Figure 10. Subsequently, as the force continues to increase, stress accumulates at the edge columns, leading to the initiation of plastic hinges there, as shown in Figure 11. Interestingly, none of the beams develop plastic hinges

prior to the complete failure of the structure. This observation underscores the concept of weak columns and strong beams. Notably, all plastic hinge formations resulting from the push-over analysis in the X direction occur at a level where collapse prevention is aimed, which poses concerns from a structural perspective (Messas, Benyahi, Adjrad, Bouafia & Benakli, 2022). This sequence of events highlights the structural vulnerabilities and potential sudden failure mechanisms associated with the analyzed system.

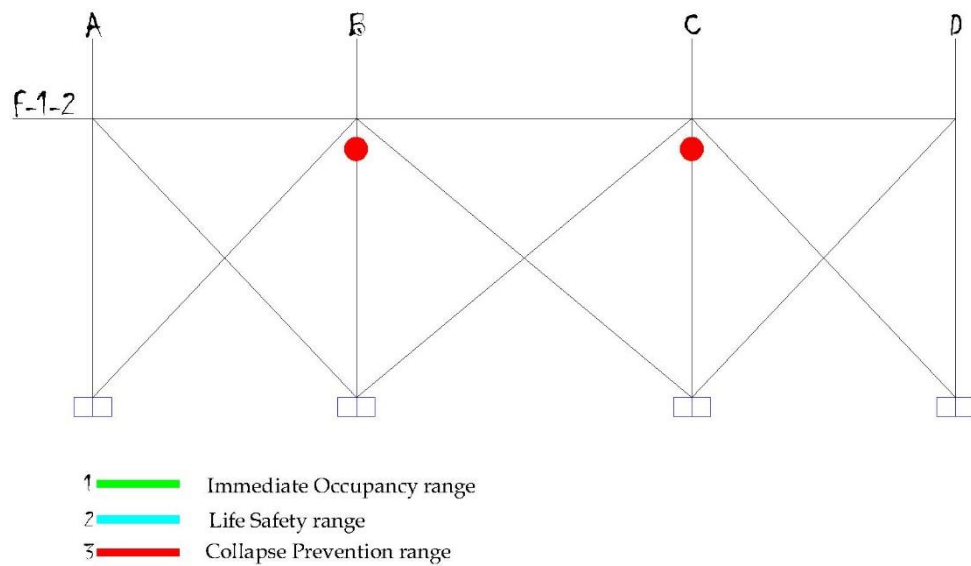

Figure 9. Plastic hinges creation as the result of pushover in X direction (Step-10, 4mm of displacement)

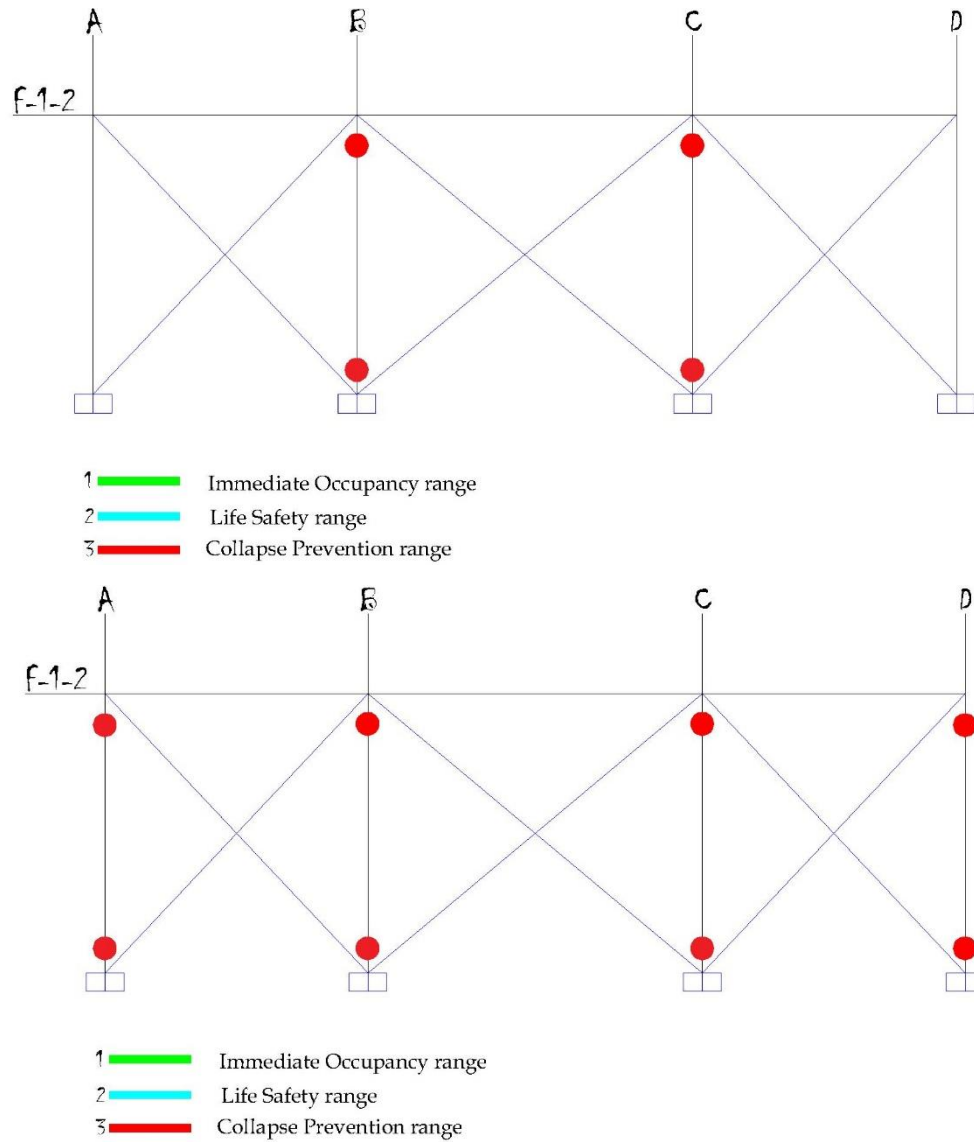

Figure 11. Plastic hinges creation as the result of pushover in X direction (Step-16, 13mm of displacement)

The outcomes of the push-over analysis in the Y direction mirror those observed in the X direction, as depicted in Figures 12, 13, and 14. However, a notable distinction is the greater flexibility of the structure in this orientation. Consequently, the failure mode in the Y direction is less abrupt compared to the X direction. This distinction becomes apparent when comparing the push-over curves for both directions, as illustrated in Figure 15. The graph interpretation reveals that the structure exhibits greater stiffness in the X direction, allowing it to withstand significant base shear forces with minimal displacement.

Conversely, in the Y direction, the structure demonstrates a slightly higher degree of flexibility. This observation underscores the directional characteristics of the structural response and emphasizes the importance of considering multi-directional loading scenarios in structural design and analysis.

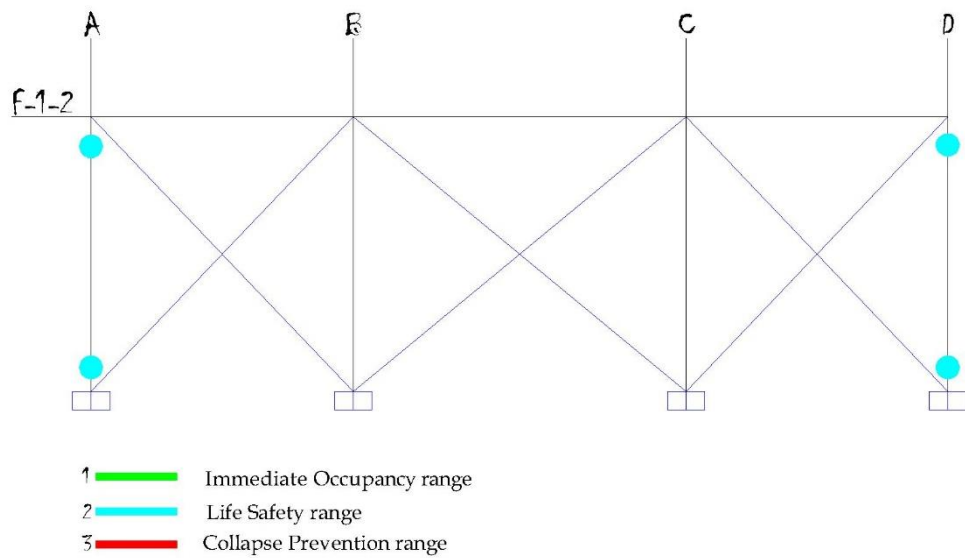

Figure 12. Plastic hinges creation as the result of pushover in Y direction (Step-6, 13mm of displacement)

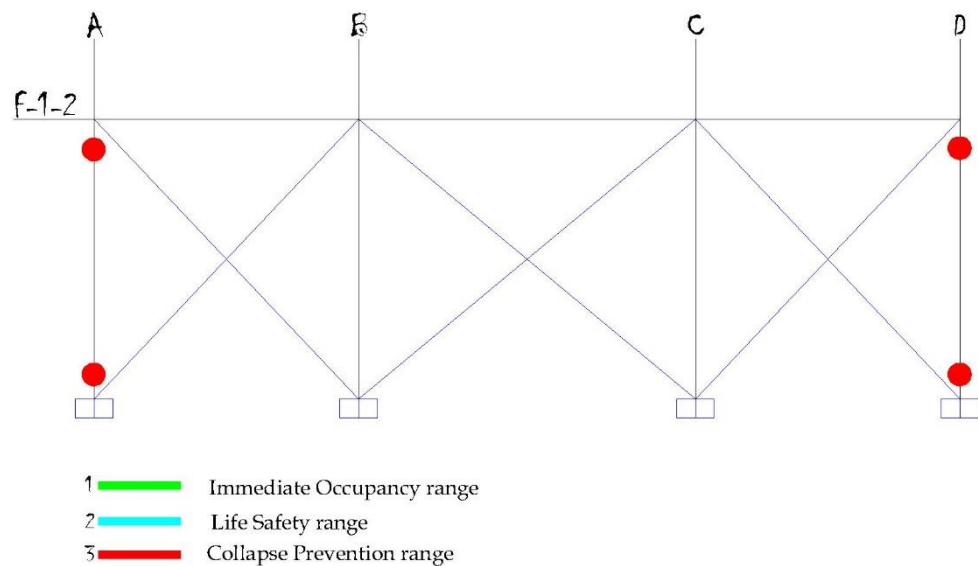

Figure 13. Plastic hinges creation as the result of pushover in Y direction (Step-9, 19mm of displacement)

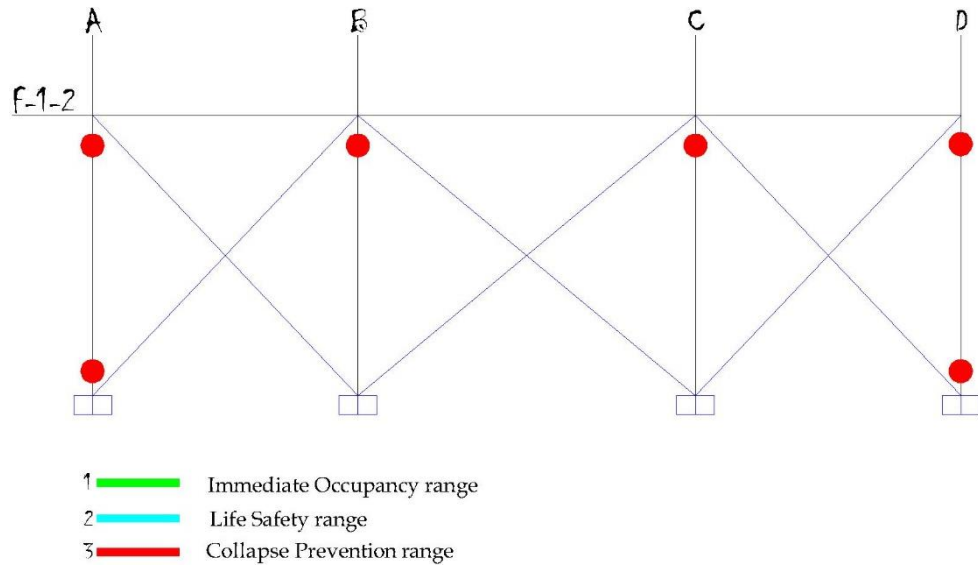

Figure 14. Plastic hinges creation as the result of pushover in Y direction (Step-10, 20mm of displacement)

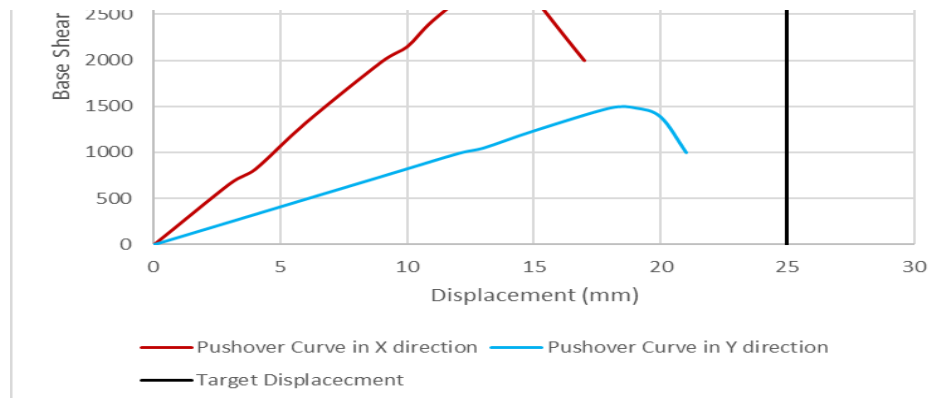

Figure 15. Push-over curve in X and Y direction with 25mm of target displacement.

Considering the outcomes of the 10 percent probability of exceedance earthquake, the 2 percent probability scenario, and the push-over analysis, it was deemed necessary to enhance the dimensions of the columns to prevent failure under seismic conditions and gravity load combinations. The recommendation is to use a column cross-section measuring 40*40cm, accompanied by reinforcement detailing outlined in Figure 16. This adjustment aims to ensure

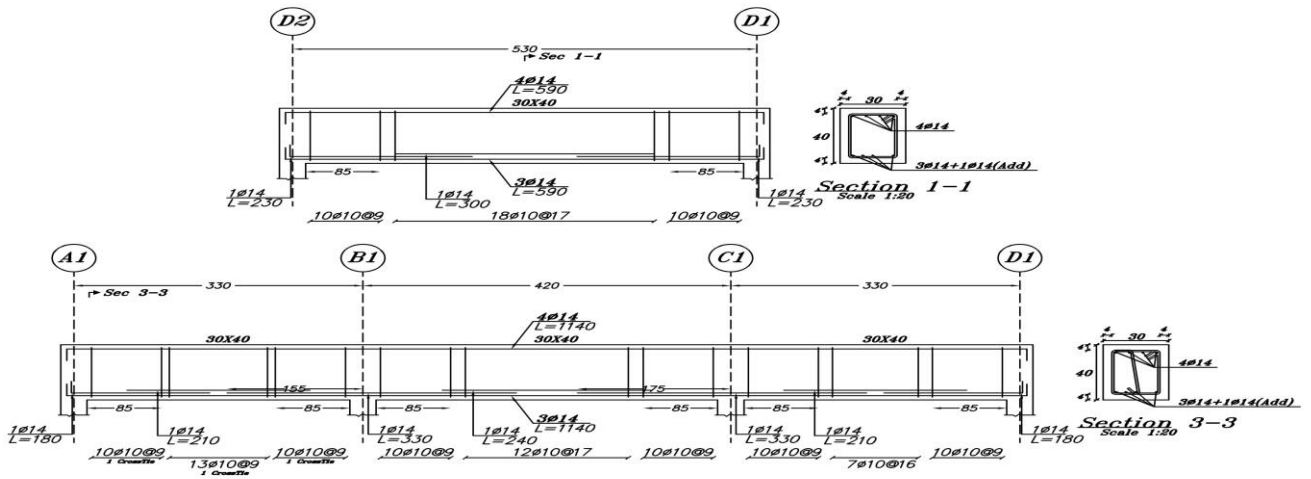

Figure 17. Shows the suggested beam detail for structure

structural integrity and resilience against potential seismic events and gravity loads, thereby enhancing the overall safety and stability of the structure. The seismic analysis suggests that to improve the behavior of the structure during earthquakes, the depth of the beams can be reduced from 45cm to 40cm as shown in figure 17. This suggestion is not only cost-effective but also promotes the concept of strong columns and weak beams. By implementing this adjustment, the structure can achieve better performance under seismic loading conditions while also potentially reducing construction costs.

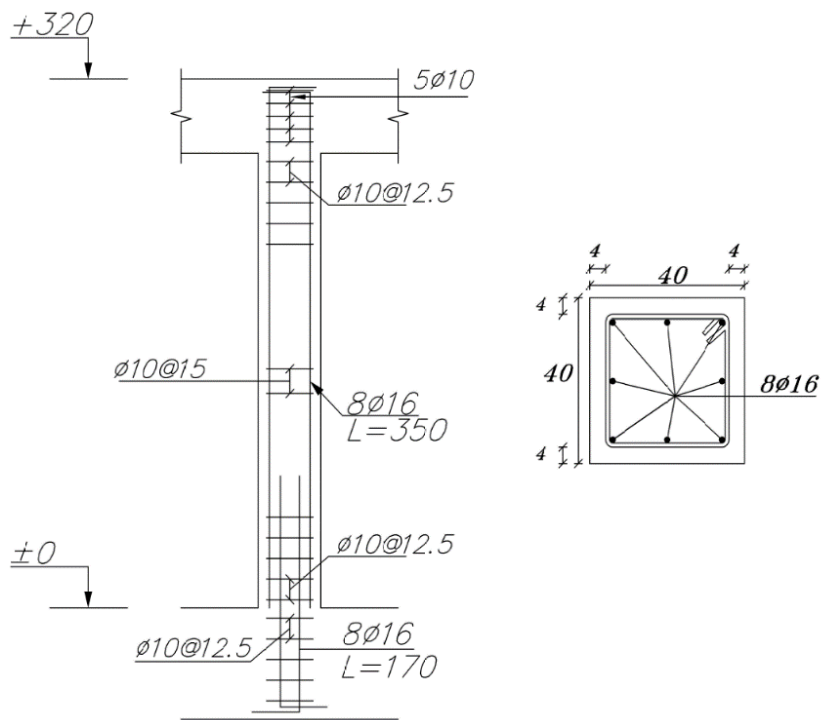

Figure 16. Shows the suggested column detail for structure

CONCLUSION

This study sought to evaluate the buildings' design weaknesses using advanced computer analyses, including Linear and Non-linear (Push-over analysis) analysis using Etabs software. Through this approach, the study aimed to identify deficiencies in the structural integrity of the newly constructed buildings, particularly focusing on the strength and stability of the members. The findings revealed significant weaknesses in certain structural elements, highlighting the importance of careful design and analysis in ensuring the safety of buildings in earthquake-prone areas that some of them are listed below.

1. The observed failure of columns under gravity load combinations underscores the possibility that the structure was not designed utilizing structural analysis software, aligning with the viewpoint shared by numerous engineers.
2. Beams demonstrated greater strength than columns, evidenced by their failure only after all columns exhibited plastic hinge formation. However, from a structural design perspective, this pattern is concerning as it could lead to sudden structural failure.
3. A detailed examination of the push-over curve suggests that opting for 40*40cm columns instead of 30*30cm columns, coupled with the omission of ground beams, would substantially enhance the structure's performance and resilience to stronger ground shaking. This optimization strategy, based on the analysis of both 2-percent and 10-percent probability scenarios as well as push-over analysis, offers potential for significant cost savings and a more robust structural design.
4. **About the authors**



Arif Alkozay holds a Bachelor's degree in Civil Engineering from the Faculty of Engineering in Herat, Afghanistan. With a focus on structural engineering research, he previously served as an assistant professor and research coordinator at the Faculty of Engineering and currently works as a Structural Designer at Sodais Saber Construction Company



Rahimullah Stanakzai holds a Bachelor's degree in Civil Engineering from the Faculty of Engineering in Herat, Afghanistan. He has previously worked as an assistant professor at faculty of Engineering. Stanakzai is currently working in Sanger Star Construction and Road Construction Company as a Designer.



Dr. Amanollah Faqiri, a distinguished academician, attained his Doctorate in Structural Engineering from the Saint Petersburg State University of Architectural and Civil Engineering in the Russian Federation. Presently assuming the role of Professor at the Faculty of Engineering in Herat province and concurrently serving as a visiting Professor at the Federal University of Gaias in Brazil, Dr. Faqiri brings a profound reservoir of expertise and scholarly acumen to both academic establishments. Spanning several decades, his professional trajectory has been committed to the discipline of structural engineering, wherein he has held professorial positions across various esteemed universities. In addition to his scholarly pursuits, Dr. Faqiri remains actively involved in the architectural design of structures within Afghanistan, thereby making substantive contributions to the region's infrastructural advancement.

Author Contribution

Arif Alkozay authored, edited, and revised the paper, as well as analyzed and interpreted the data. Rahimullah Stanakzai contributed to data analysis and interpretation, as well as assisting in writing the paper. Amanollah Faqiri reviewed and revised the paper for accuracy and coherence.

REFERENCES

- Wikipedia Contributors. (2019, March 2). *Earthquake*. Wikipedia; Wikimedia Foundation. <https://en.wikipedia.org/wiki/Earthquake>
- Moore, A. (2023, February 23). *Why the Turkey-Syria Earthquakes Were So Destructive*. College of Natural Resources News. <https://cnr.ncsu.edu/news/2023/02/turkey-syria-earthquakes/>
- Ghobarah, A. (2001). Performance-based design in earthquake engineering: state of development. *Engineering structures*, 23(8), 878-884.
- Alkozay, A. (2023). Public Awareness and Perception of Earthquake Hazard: A Case Study in Herat Province. *International Journal of Multidisciplinary Research and Publications (IJMRAP)*, 6(6), 95-102. <http://ijmrmap.com/wp-content/uploads/2023/12/IJMRAP-V6N6P73Y23.pdf>
- USGS. "Can We Cause Earthquakes? Is There Any Way to Prevent Earthquakes?" Usgs.gov, 2016, www.usgs.gov/faqs/can-we-cause-earthquakes-there-any-way-prevent-earthquakes.
- "2023 Herat Earthquakes." Wikipedia, 12 Oct. 2023, en.wikipedia.org/wiki/2023_Herat_earthquakes.
- (2024). Usgs.gov. <https://earthquake.usgs.gov/earthquakes/eventpage/us6000ldpm>
- Boyd, O. S., Mueller, C. S., & Rukstales, K. S. (2007). Preliminary earthquake hazard map of Afghanistan. *US Geological Survey Open-File Report, 2007*, 1137.
- Leslie, R. (2013). The pushover analysis, explained in its simplicity. In *National Conference (Recent Advances in Civil Engineering) RACE* (Vol. 13).
- Themelis, S. (2008). Pushover analysis for seismic assessment and design of structures (Doctoral dissertation, Heriot-Watt University).
- Di Julio, R. M. (2001). Linear static seismic lateral force procedures. *The seismic design handbook*, 247-273.
- Messas, A., Benyahi, K., Adjrad, A., Bouafia, Y., & Benakli, S. (2022). Effect of the capacity ratio developed at column-beam nodes and evaluation of its random degradation impact on the formation of global ruin mechanisms. *World Journal of Engineering*, 19(5), 605-619.